

**Guardian 500VA, 10kVAC & 12kVDC  
Hipot Testers  
Instruction Manual  
Form 150514/A7**

©QuadTech, Inc., 2000  
5 Clock Tower Place, 210 East  
Maynard, Massachusetts, U.S.A. 01754  
April 2004

Telephone	978-461-2100
Sales	800-253-1230
Facsimile	978-461-4295
Website	<a href="http://www.quadtech.com">www.quadtech.com</a>

The material in this manual is for informational purposes only and is subject to change, without notice. QuadTech assumes no responsibility for any error or for consequential damages that may result from the misinterpretation of any procedures in this publication.

**WARNING**

Potentially dangerous voltages may be present on front and rear panel terminals. Follow all warnings in this manual when operating or servicing this instrument. Dangerous levels of energy may be stored in capacitive devices tested by this unit. Always make sure the high voltage indicator is **not** on when connecting or disconnecting the device under test.



Product will be marked with this symbol (ISO#3864) when it is necessary for the user to refer to the instruction manual in order to prevent injury or equipment damage.



Product marked with this symbol (IEC417) indicates presence of direct current.



Product will be marked with this symbol (ISO#3864) when voltages in excess of 1000V are present.



---

# Contents

---

<b>Warranty</b>	<b>7</b>
<b>Specifications</b>	<b>9</b>
<b>Accessories</b>	<b>13</b>
<b>Safety Precautions</b>	<b>15</b>
<b>Condensed Operating Instructions</b>	<b>17</b>
<b>Introduction - Section 1</b>	
1.1	Unpacking and Inspection.....21
1.2	Product Overview .....21
1.3	Controls and Indicators .....22
1.3.1	Front Panel Controls and Indicators .....22
1.3.2	Rear Panel Controls and Connectors .....24
1.4	Installation .....26
1.4.1	Dimensions .....26
1.4.2	Instrument Positioning .....26
1.4.3	Power Requirements .....26
1.4.4	Safety Inspection.....28
<b>Operation - Section 2</b>	
2.1	Terms and Conventions .....29
2.2	Start-Up.....33
2.3	Programming Hipot Tests .....34
2.3.1	Programming an AC Hipot Test .....34
2.3.2	Programming a DC Hipot Test .....35
2.4	Programming an Insulation Resistance Test.....36
2.5	Programming a Pause .....37
2.6	Programming a Multi-Step Test .....38
2.7	Memory Management .....39
2.7.1	Storing a Single Step Test.....39
2.7.2	Storing a Multi-Step Test.....40
2.7.3	Recalling a Test Setup .....41
2.7.4	Deleting a Test Setup .....41
2.8	Instrument Zeroing/Offset.....41
2.9	Connection To Device Under Test.....43
2.10	Measurement Procedure.....46
2.10.1	Viewing Test Results .....46

---

## Contents (Continued)

---

### Operation - Section 2 (Continued)

2.11	Initial Parameter Setting .....	47
2.11.1	General Setting .....	50
2.11.1.1	Contrast .....	50
2.11.1.2	Beep Vol. ....	50
2.11.1.3	Scan Box No. ....	50
2.11.1.4	Fail Retest .....	50
2.11.1.5	Print PASS .....	50
2.11.1.6	Print FAIL .....	50
2.11.1.7	Timer U/D .....	51
2.11.2	Timing Setting .....	51
2.11.2.1	Pass Hold .....	51
2.11.2.2	Step Hold .....	51
2.11.2.3	Judg. Wait .....	51
2.11.2.4	DC Wait .....	51
2.11.3	Special Setting .....	52
2.11.3.1	AC-V Freq .....	52
2.11.3.2	Auto Range .....	52
2.11.3.3	Soft. AGC .....	52
2.11.3.4	Password .....	52
2.11.3.5	Lockout Recall .....	54
2.11.3.6	Discharge .....	54
2.11.4	Remote Setting .....	54
2.11.4.1	GPIB Addr. ....	54
2.11.4.2	Baud Rate .....	54
2.11.4.3	GPIB Comp. ....	54
2.12	Front Panel Lockout.....	55
2.13	Software Version Display .....	55
2.14	Clear Setup Memory .....	56

### Interface - Section 3

3.1	Remote .....	57
3.2	RS232 Interface.....	60
3.2.1	PIN Configuration .....	60
3.2.2	RS232 Specifications .....	61
3.2.3	RS232 Commands .....	61
3.2.4	Sample QuickBASIC Program .....	62
3.3	IEEE-488 Interface .....	63
3.3.1	PIN Configuration.....	63
3.3.2	IEEE-488 Interface Codes and Messages .....	64
3.3.3	Interface Commands .....	65
3.3.4	Listener Functions.....	66
3.3.5	Talker Functions .....	71
3.3.6	Sample QuickBASIC Program .....	74

---

## Contents (Continued)

---

### Interface - Section 3 (Continued)

3.4	Printer Interface .....	76
3.5	Scanner Interface.....	77
	3.5.1 Scanner Accessories.....	77
	3.5.2 Scanner Card Installation .....	77
	3.5.3 Scanner Connections.....	78
	3.5.4 External Scanner Programming .....	79
3.6	G16 International Power Strip .....	81
3.7	S07 Power Entry Adaptor Cable .....	82
3.8	S03 Corded Product Adaptor .....	83

### Service & Calibration - Section 4

4.1	General.....	85
4.2	Instrument Return .....	85
4.3	Calibration.....	85
	4.3.1 Calibration Procedure .....	86
	<b>4.3.2 Guardian 500VA Calibration .....</b>	<b>87</b>
	4.3.2.1 AC Voltage Calibration .....	88
	4.3.2.2 DC Voltage Calibration .....	89
	4.3.2.3 IR Voltage Calibration .....	90
	4.3.2.4 AC Current Calibration .....	91
	4.3.2.5 DC Current Calibration.....	93
	4.3.2.6 WAC & WDC ARCing Calibration .....	95
	4.3.2.7 IR Resistor Calibration .....	96
	4.3.2.7 Finalize Calibration .....	98
	<b>4.3.3 Guardian 10kVAC Calibration .....</b>	<b>99</b>
	4.3.3.1 AC Voltage Calibration .....	100
	4.3.3.2 AC Current Calibration .....	101
	4.3.3.3 WAC ARCing Calibration .....	103
	4.3.3.4 Finalize Calibration .....	103
	<b>4.3.4 Guardian 12kVDC Calibration .....</b>	<b>104</b>
	4.3.4.1 DC Voltage Calibration .....	105
	4.3.4.2 IR Voltage Calibration .....	106
	4.3.4.3 DC Current Calibration .....	107
	4.3.4.4 WDC ARCing Calibration .....	109
	4.3.4.5 IR Resistor Calibration .....	110
	4.3.4.6 Finalize Calibration .....	112
4.4	Error Messages .....	112



---

## Warranty

---



QuadTech warrants that Products are free from defects in material and workmanship and, when properly used, will perform in accordance with QuadTech's applicable published specifications. If within one (1) year after original shipment it is found not to meet this standard, it will be repaired, or at the option of QuadTech, replaced at no charge when returned to a QuadTech service facility.

**Changes in the Product not approved by QuadTech shall void this warranty.**

**QuadTech shall not be liable for any indirect, special or consequential damages, even if notice has been given of the possibility of such damages.**

**This warranty is in lieu of all other warranties, expressed or implied, including, but not limited to any implied warranty or merchantability or fitness for a particular purpose.**

### SERVICE POLICY

QuadTech's service policy is to maintain product repair capability for a period of at least five (5) years after original shipment and to make this capability available at the then prevailing schedule of charges.





# Specifications

## Dielectric Strength

Test Parameter	10kVAC	12kVDC	500VA
	AC/ARC	DC/IR/ARC	AC/DC/IR/ARC
<b>AC</b>			
Voltage Range	0.1kV – 10kV		0.05kV – 5kV
Accuracy	±(1% + 10V)		±(1% + 10V)
Current Range	0.001mA – 20mA, 1μA		0.001mA – 100mA, 1μA
Accuracy	±(1% + 5μA or 50μA)		±(1% + 5 counts)
<b>DC</b>			
Voltage Range		0.1kV – 12kV	0.05kV – 6kV
Accuracy		±(1% + 10V)	±(1% + 5V)
Current Range		0.001mA – 10mA, 0.1μA	0.1μA – 20mA, 0.1μA
Accuracy		±(1% + 5μA or 50μA)	±(1% + 5μA or 50μA)
<b>IR</b>			
Voltage Range		100V – 1000V	100V – 1000V
Accuracy		±(5% + 10V)	±(5% + 5V)
Resistance		100kΩ - 50GΩ	100kΩ - 50GΩ
Accuracy		100KΩ -1GΩ<500V: ±10%	100KΩ -1GΩ<500V: ±10%
		10MΩ -1GΩ≥500V: ±5%	10MΩ -1GΩ≥500V: ±5%
		1GΩ -10GΩ≥500V: ±10%	1GΩ -10GΩ≥500V: ±10%
		10GΩ -50GΩ≥500V: ±15%	10GΩ -50GΩ≥500V: ±15%
<b>ARC</b>			
Current Range	1mA – 20mA	1mA – 10mA	1mA – 100mA (20mA DC)
Pulse Width	10μS minimum	10μS minimum	10μS minimum

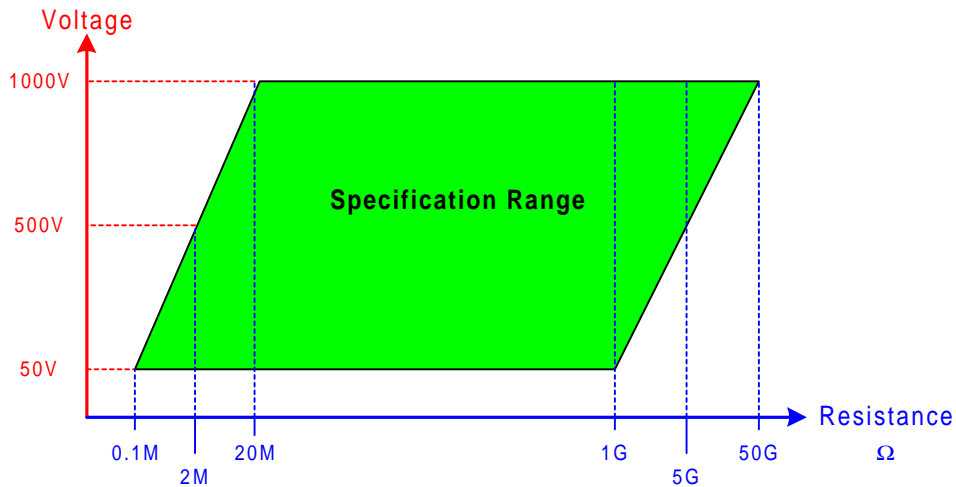

**G12kV DC & G500VA Resistance Specification Range**

---

## Specifications (Continued)

---

### General Features

---

<b>Limits:</b>	Hi/Lo Programmable during Test Time (Lo can be set to Off for Hipot & GC, Hi can be set to Off for IR)
<b>Indication:</b>	Pass/Fail LEDs, audible sound
<b>Buzzer Level:</b>	1,2,3, OFF
<b>Time:</b>	Test Time: 0.1 to 999sec ( $\pm 20$ ms) [Set time or Continuous] Ramp Time: 0.1 to 999sec ( $\pm 20$ ms) [Set time or OFF]
<b>Remote Control:</b>	Inputs: START, RESET Characteristics: 24V active low, Pulse width >1ms Outputs: PASS, FAIL, UNDER TEST Characteristics: Dry contact relay, Closed if true 120V, 100mA max Connector: 9 pin male D-series & Terminal Strip
<b>Setup Storage:</b>	99 Memory Groups (include 99 steps each)
<b>Optional Interfaces:</b>	<ul style="list-style-type: none"><li>• IEEE-488</li><li>• RS232</li><li>• Scanner (G500VA unit only)</li><li>• Printer(replaces IEEE-488 interface)</li></ul>
<b>Optional External Scanner:</b>	Guardian 5000-01 and 5000-03 Scan units Rated for 5kVAC, 6kVDC
<b>Connectors:</b>	Front and Rear Connection (Binding Post/Banana Plug Terminals)
<b>Front Panel Lockout:</b>	6 Digit Password with or without setup recall LED Display "KeyLock"

---

## Specifications (Continued)

---

### General Features

---

<b>Mechanical:</b>	Bench Mount (optional rack mount flanges available, G-27) Dimensions:(w x h x d):16.875 x 5.625 x 18.625 inches (421.875 x 140.625 x 465.625 mm)									
<b>Weight:</b>	Guardian 500VA	53 lbs (24kg) net, 60 lbs (27kg) shipping								
	Guardian 10kVAC	44 lbs (20kg) net, 51 lbs (23kg) shipping								
	Guardian 12kVDC	44 lbs (20kg) net, 51 lbs (23kg) shipping								
<b>Environmental:</b>	Meets MIL-T-28800E, Type 3, Class 5 Operating: 0°C to + 40°C Storage: -20° to + 70°C Humidity: <75% Warm-up Time: 15 minutes									
<b>Power:</b>	<ul style="list-style-type: none"><li>• 90 - 130V AC</li><li>• 200 - 250V AC*</li><li>• 50 or 60Hz</li></ul>	<ul style="list-style-type: none"><li>• 600W max 10kVAC &amp; 12kVDC</li><li>• 1500W max 500VA</li></ul>								
<b>Supplied:</b>	<ul style="list-style-type: none"><li>• Instruction Manual</li><li>• Calibration Certificate</li></ul>	<ul style="list-style-type: none"><li>• Power Cable</li><li>• Test Leads (2)</li></ul>								
<b>Ordering Information:</b>	<table border="1"><thead><tr><th><u>Description</u></th><th><u>Catalog No.</u></th></tr></thead><tbody><tr><td>Guardian 500VA AC/DC/IR Hipot Tester</td><td>Guardian 500VA</td></tr><tr><td>Guardian 10kVAC AC Hipot Tester</td><td>Guardian 10kVAC</td></tr><tr><td>Guardian 12kVDC DC/IR Hipot Tester</td><td>Guardian 12kVDC</td></tr></tbody></table>	<u>Description</u>	<u>Catalog No.</u>	Guardian 500VA AC/DC/IR Hipot Tester	Guardian 500VA	Guardian 10kVAC AC Hipot Tester	Guardian 10kVAC	Guardian 12kVDC DC/IR Hipot Tester	Guardian 12kVDC	
<u>Description</u>	<u>Catalog No.</u>									
Guardian 500VA AC/DC/IR Hipot Tester	Guardian 500VA									
Guardian 10kVAC AC Hipot Tester	Guardian 10kVAC									
Guardian 12kVDC DC/IR Hipot Tester	Guardian 12kVDC									

\* G500VA Only: Not recommended for output power >250VA for prolonged use.



## Accessories

### Accessories Included

Item	Quantity	QuadTech P/N
AC Power Cord	1	4200-0300
Power Line Fuse 6.3A 250V (500VA, 10kV & 12kV)	1	520071
Power Line Fuse 3.15A 250V (10kV & 12kV only)	1	520072
Power Line Fuse 15A 250V (500VA only)	1	
High Voltage Lead Set, 1m with alligator clips	1	S02
Power Entry Adapter Cable	1	S07*
Instruction Manual	1	150514
Calibration Certificate	1	N/A

### Accessories/Options Available

Item	Quantity	QuadTech P/N
High Voltage Lead Set, high & low, 1m (std. with unit)	1	S02
High Voltage Lead Set, high & low, 2m	1	S04
High Voltage Lead, 1m, unterminated	1	S09
High Voltage Lead, 2m, unterminated	1	S10
Corded Product Adaptor (115V)	1	S03*
Power Entry Adaptor Cable	1	S07*
Foot Switch	1	S05
High Voltage Probe	1	S06*
Gun Probe	1	S08*
Gun Probe with Remote Start	1	S11*
Load Box, resistive	1	S12
Load Box, custom resistors	1	S14
Power Entry Adaptor Cable	1	G14*
International Power Strip	1	G16*
Corded Product Adapter (230V)	1	G25*
Rack Mount Flanges	1	G27
RS232 Interface	1	G26
Printer Interface	1	G28
IEEE-488 (GPIB) Interface	1	G29

\* Max Voltage Rating is 5kVAC & 6kVDC



---

## Safety Precautions

---

### WARNING

The Guardian 10kVAC, 12kVDC & 500VA Hipot Testers can provide an output voltage as high as 10kVAC, 12kVDC & 6kVDC respectively to the device under test.

Although each Guardian unit is designed with full attention to operator safety, serious hazards could occur if the instrument is used improperly and these safety instructions are not followed.

1. The Guardian 10k/12k/500VA units are designed to be operated with their chassis connected to earth ground. Each instrument is shipped with a three-prong power cord to provide this connection to ground. This power cord should only be plugged in to a receptacle that provides earth ground. Serious injury can result if the Guardian unit is not connected to earth ground.
2. Tightly connect cable(s) to the (black) GND terminal. If this is not done, the DUT's casing can be charged to the high voltage test level and serious injury or electrical shock hazards could result if the DUT is touched.
3. Never touch the metal of the High Voltage probe directly. Touch only the insulated parts of the lead(s).
4. Never touch the test leads, test fixture or DUT in any manner (this includes insulation on all wires and clips) when the high voltage is applied and the red **DANGER** light is ON.
5. Before turning on the Guardian unit, make sure there is no device (DUT) or fixture connected to the test leads.
6. After each test, press the red [**STOP**] button for safety. This terminates the high voltage being applied to the output terminals.
7. When the red **DANGER** LED is ON or flashing, NEVER touch the device under test, the lead wires or the output terminals.
8. Before touching the test lead wires or output terminals make sure :
  - a) The red [**STOP**] button has been pressed.
  - b) The red **DANGER** LED is OFF.
9. In the case of an emergency, turn OFF the [**POWER**] switch using a "hot stick" and disconnect the AC power cord from the wall. **DO NOT TOUCH THE Guardian INSTRUMENT.**
10. If the **DANGER** LED does not go OFF when the [**STOP**] button is pressed, immediately stop using the tester. It is possible that the output voltage is still being delivered regardless of the TEST ON/OFF control signal.
11. Be extremely careful when the Guardian 10k, 12k or 500VA instrument is used in remote control mode. The High Voltage Output is being turned on and off with an external signal.
12. For the G500VA instrument only: If the output power is greater than 250VA, then the power input should be 220/240V to avoid internal failure.





---

# Condensed Operating Instructions

---

## WARNING

High Voltage is applied to the white H.V. output terminal anytime the red **DANGER** LED is lit or flashing. Always make sure the **DANGER** LED is OFF when connecting or disconnecting the Device Under Test (DUT).

## General Information

The Guardian 10kVAC Hipot tester measures AC output voltage over a 0.1 to 10kVAC range. The AC current limit is adjustable from 1 $\mu$ A to 20mA AC in 1 $\mu$ A or 10 $\mu$ A steps. The Guardian 12kVDC unit measures DC output voltage over a 0.1kV to 12kVDC range. The DC current limit is adjustable from 1 $\mu$ A to 10mA. The Guardian 12kVDC unit also measures insulation resistance of 1M $\Omega$  to 50G $\Omega$  over a 100V to 1kV range. The Guardian 500VA unit measures AC & DC output voltage and insulation resistance. The voltage applied to the device under test is adjustable from 0.05 to 5kVAC (6kVDC). The current limit is adjustable from 0.1 $\mu$ A to 100mA AC (20mA DC) in 1 $\mu$ A or 10 $\mu$ A steps. The Guardian 500VA unit also measures insulation resistance of 1M $\Omega$  to 50G $\Omega$  over a 50V to 1kV range. PASS and FAIL LEDs provide a visual display of test results based on preset limits.

## Start-Up

The Guardian units can be operated from a power source between 90 and 250VAC at a power line frequency of 50 or 60Hz. The G10kVAC & G12kVDC units are shipped from QuadTech with a 6.3A fuse in place for AC 90-130V operation. (A 3.15A fuse is included for 200-250V operation). The G500VA unit is shipped with a 15A fuse in place for 90-130V operation. (A 6.3A fuse is included for 200-250V operation). All Guardian units are shipped with the line voltage selector set for 120V. If the G500VA power source is to exceed 250VA, then the power source must be 220/240V. Refer to paragraph 1.4.3 to change a fuse and to change the line voltage selector.

Connect the Guardian unit AC power cord to the source of proper voltage. The Guardian instrument is designed to be operated with its chassis connected to earth ground. Each Guardian unit is shipped with a three prong power cord to provide this connection to ground. This power cord should only be plugged in to a receptacle which provides earth ground. Serious injury can result if the Guardian instrument is not connected to earth ground.

Press the [POWER] button on the front panel to apply power. To switch the power off press the [POWER] button again or if measurements are to be made proceed with Test Parameter Set-Up below. Note: the Guardian instrument should warm-up for a minimum of 15 minutes prior to use.

# Condensed Operating Instructions

## Test Parameter Set-Up

Press [PROG] and enter the Test Parameters according to your test specification.

Test	Test Mode	V Test (KV)	IR HI R (MΩ)	I HI Limit (mA)	IR LO R (MΩ)	I LO Limit (mA)	ARC Detect (mA)	Test Time (sec)	Ramp Time (sec)
AC Hipot	SET	SET		SET		SET	SET	SET	SET
DC Hipot	SET	SET		SET		SET	SET	SET	SET
Insulation Resistance	SET	SET	SET		SET			SET	SET

### NOTE

Refer to paragraphs 2.3.1, 2.3.2, 2.4, 2.5, 2.6 and 2.7 for a full description of programming test parameters and instruction on how to store the test setup. Test parameters must be set **before** the Guardian unit can be zeroed.

## Zeroing/Offset

After setting your test parameters, zero the Guardian unit by using the automatic offset. With no device connected, connect the appropriate cable (or other fixture) to the front panel OUTPUT connectors. Refer to paragraph 2.8 for cable connections based on tests to be made. Test leads for AC Hipot, DC Hipot and IR measurements should be OPEN and test leads for GR should be SHORTED.

Press OFFSET key once. Display reads “Offset is GET. Press Test Key”. Press [TEST] key once. Display shows your test set-up. Press [OFFSET] key once. Display shows your offset. Offset has to be recalculated each time you change your test parameters, test leads or test fixture.

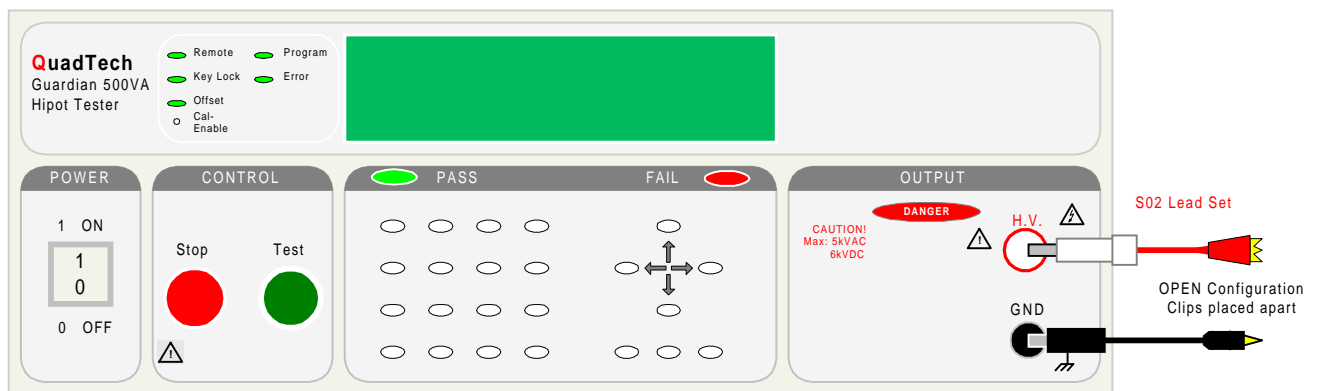

**Figure COI-1: Zero/Offset Connection for AC Hipot, DC Hipot, & IR**

---

# Condensed Operating Instructions

---

## Measurement Mode

The Guardian 10kVAC Hipot Tester measures AC Hipot. The Guardian 12kVDC Hipot Tester measures DC Hipot and Insulation Resistance. The Guardian 500VA measures AC Hipot, DC Hipot and Insulation Resistance. Refer to paragraph 2.9 for the appropriate cable connection to the device under test. Refer to paragraphs 2.3.1, 2.3.2, 2.4, 2.5, and 2.6 for instruction on programming a test listed above.

### AC Hipot Measurement Example:

- 1 Turn Power ON.
- 2 Allow Guardian unit to warm-up for 15 minutes.
- 3 Connect Black ground cable to Guardian GND terminal.
- 4 Connect Red high voltage cable to Guardian H.V. terminal.
- 5 Press [PROG] and enter your Test Parameters Press [PROG] again to accept it.
- 6 STORE Test set-up (If desired).
- 7 Connect test cables in OPEN configuration.
- 8 Press [OFFSET] then [TEST] to Zero the Guardian unit.
- 9 Connect Device Under Test (DUT).
- 10 Press red [STOP] button.
- 11 Press green [TEST] button.
- 12 Record Readings.
- 13 Press red [STOP] button.

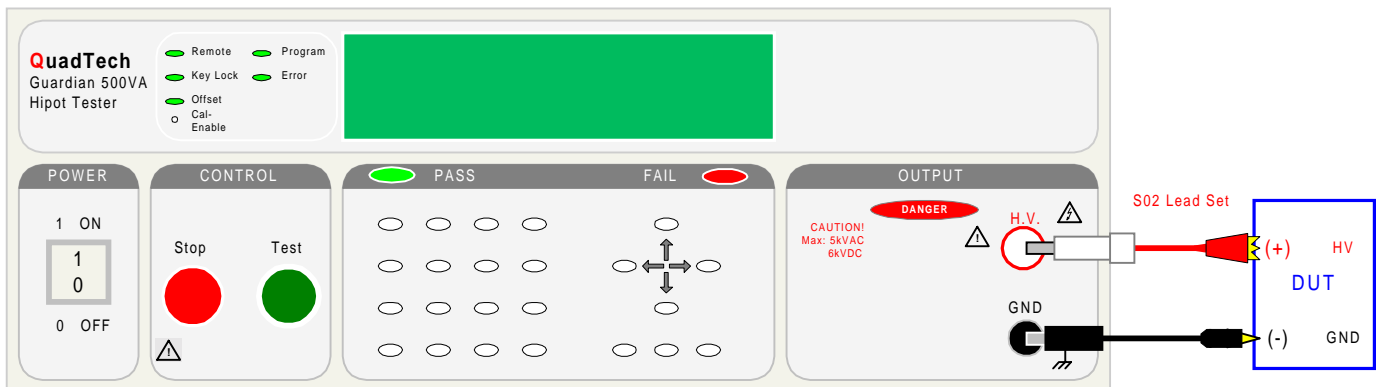

Figure COI-2: S02 Cable Connection To Device Under Test



---

# Section 1 : Introduction

---

## 1.1 Unpacking and Inspection

Inspect the shipping carton before opening. If damaged contact the carrier agent immediately. Inspect the Guardian instrument for any damage. If the instrument appears damaged or fails to meet specifications notify QuadTech (refer to instruction manual front cover) or its local representative. Retain the shipping carton and packing material for future use such as returning for recalibration or service.

## 1.2 Product Overview

The Guardian 500VA Hipot Tester combines three critical safety tests into a single instrument: AC hipot, DC hipot, and Insulation Resistance. The hipot test can be programmed over a voltage range of 0.05 to 5kV AC and 0.05 to 6kV DC with a min/max current detection range of 1 $\mu$ A to 100mA AC and 0.1 $\mu$ A to 20mA DC. Insulation resistance measurements are possible to 50G $\Omega$  at programmable DC test voltages between 50 and 1000V. The Guardian 12kVDC Hipot Tester measures DC hipot and Insulation Resistance. The DC hipot test can be can programmed over a voltage range of 0.1 to 12kV DC with a min/max current detection range of 1 $\mu$ A to 10mA DC. Insulation resistance measurements are possible to 50G $\Omega$  at programmable DC test voltages between 100 and 1000V. The Guardian 10kVAC Hipot Tester measures AC hipot. The AC hipot test can be can programmed over a voltage range of 0.1 to 10kV AC with a min/max current detection range of 1 $\mu$ A to 20mA AC. Each Guardian instrument comes standard with internal storage of up to 99 memory groups. Optional interfaces available for the Guardian 500VA, 10kVAC and 12kVDC units include an IEEE-488 interface, an RS232 interface or a Printer interface. A scanner interface is available for use with the G500VA unit only.

### **WARNING: HIGH VOLTAGE**

The Guardian 500VA is capable of generating up to 6000VDC.

The Guardian 10kVAC is capable of generating up to 10,000VAC.

The Guardian 12kVDC is capable of generating up to 12,000VDC.

Do NOT touch the Test Terminals when the red **DANGER** LED is ON.

Always make sure the **DANGER** LED is OFF when connecting or disconnecting the device under test (DUT)

## 1.3 Controls and Indicators

### 1.3.1 Front Panel Controls and Indicators

Figure 1-1 illustrates the controls and indicators on the front panel of the Guardian 500VA instrument. The Guardian 10kVAC and 12kVDC instruments have the same front panel with the exception of the Maximum Voltage Caution Warning and Model Number. Figure 1-2 is a detailed illustration of the key pad (4a-y of Figure 1-1). Table 1-1 identifies the controls and indicators with descriptions and functions.

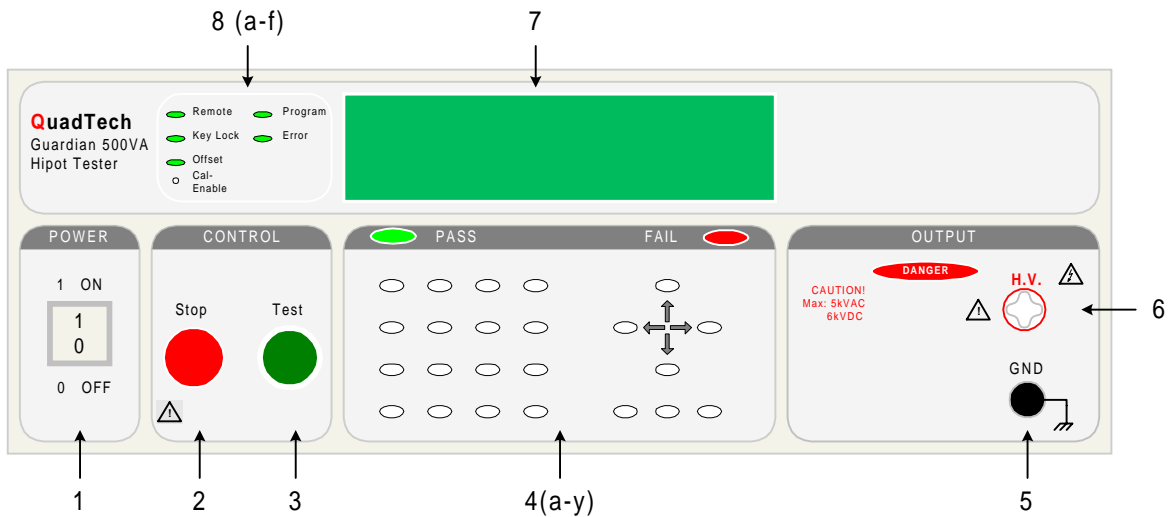

**Figure 1-1: Front Panel Controls & Indicators**

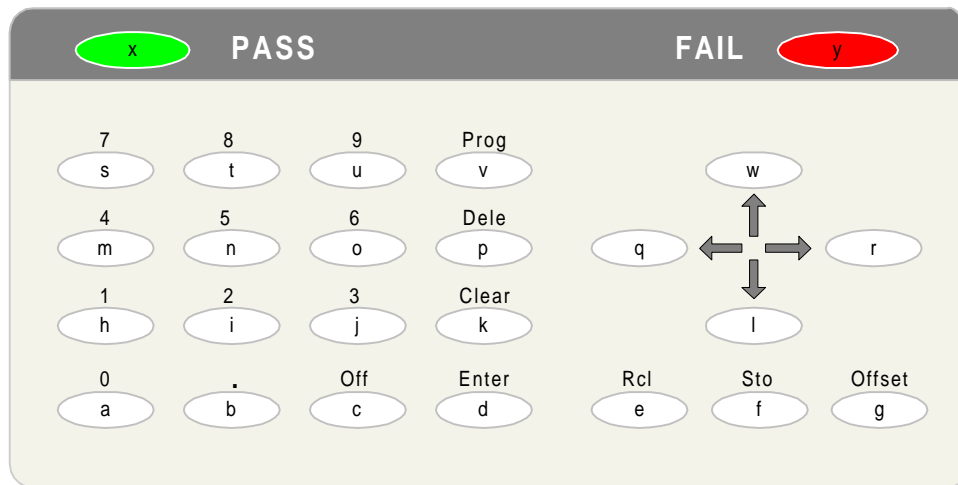

**NOTE:** The lower case letters inside the white buttons are for identification purposes only. They do **NOT** appear on the instrument.

**Figure 1-2: Close-Up Guardian Key Pad (4a-y)**

**Table 1-1 : Guardian Front Panel Controls and Indicators**

Reference Number Figures 1-1 and 1-2	Name	Type	Function
1	POWER	Grey Toggle Switch	Applies AC power to unit, 0=OFF, 1=ON
2	<b>STOP</b>	Red Push Button	Stops the test in progress. Reset function : Stop <b>MUST</b> be pressed before green Test button.
3	TEST	Green Push Button	Starts a test and applies high voltage to the Test Terminals.
4	Key Pad	White Push Buttons	To program test information.
4a	0 key	White P-B	Numerical key
4b	.	White P-B	Decimal key
4c	Off	White P-B	Turn test parameters OFF ( limits, arc)
4d	Enter	White P-B	To enter test parameters
4e	Rcl	White P-B	To recall stored test parameters (1-99) from memory
4f	Sto	White P-B	To store test parameters (1-99) from memory
4g	Offset	White P-B	To initiate zeroing (offset) function
4h	1	White P-B	Numerical key
4i	2	White P-B	Numerical key
4j	3	White P-B	Numerical key
4k	Clear	White P-B	To cancel parameter number and input again
4l	↓	White P-B	To examine steps 1-99, To ↓ test voltage, To change status
4m	4	White P-B	Numerical key
4n	5	White P-B	Numerical key
4o	6	White P-B	Numerical key
4p	Dele	White P-B	To delete a test step, those below move up
4q	←	White P-B	Under PROG, To select parameter for programming
4r	→	White P-B	Under PROG, To select parameter for programming
4s	7	White P-B	Numerical key
4t	8	White P-B	Numerical key
4u	9	White P-B	Numerical key
4v	Prog	White P-B	To enter and exit parameter setting status
4w	↑	White P-B	To examine steps 1-99, To ↑ test voltage, To change status
4x	PASS	Green LED	When lit, indicates PASS result of programmed test
4y	<b>FAIL</b>	Red LED	When lit, indicates FAIL result of programmed test
5	GND	Black Banana Plug Rec.	Ground Reference for ALL Tests
6	H.V.	White Custom Banana	High Voltage Output Terminal (Hipot & IR )
7	Display		Indicates step, mode, limits, test setup, test result
8	Indicators		
8a	Remote	Green LED	When lit indicates Remote test being performed
8b	Key Lock	Green LED	When lit, indicates the key pad is locked out
8c	Offset	Green LED	When lit, indicates Offset is ON
8d	Program	Green LED	When lit, indicates Program function enabled
8e	Error	Green LED	When lit, indicates Error in entering test information
8f	Cal Enable	Pin sized hole	Used by Qualified Service Personnel for unit calibration

### 1.3.2 Rear Panel Controls and Indicators

Figure 1-3 illustrates the controls and indicators on the rear panel of the Guardian 500VA. The Guardian 10kVAC and 12kVDC instruments have the same rear panel configuration. Figure 1-4 is a detailed illustration of the remote connectors on the rear panel of the Guardian 500VA instrument. Table 1-2 identifies them with description and function.

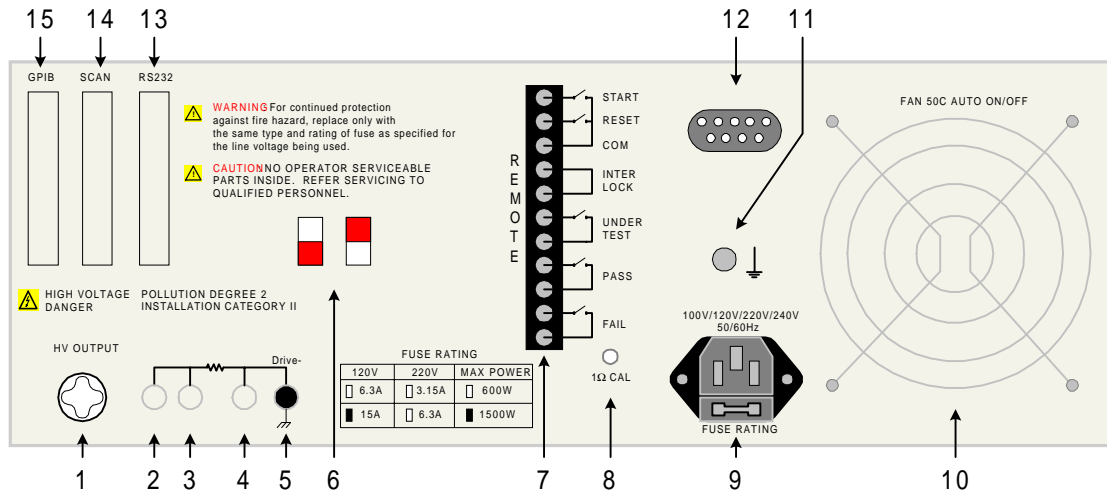

**Figure 1-3: Rear Panel Controls and Indicators**

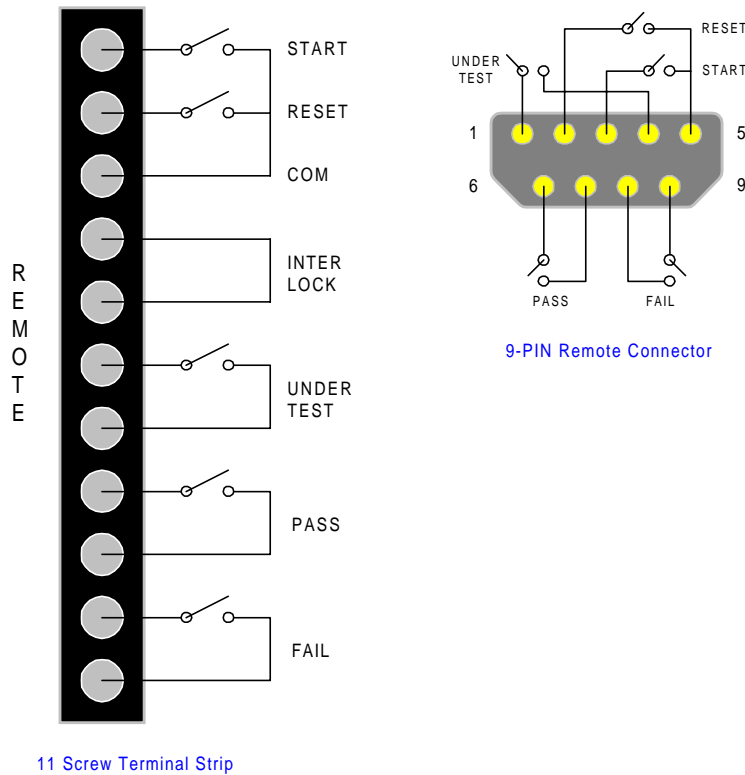

**Figure 1-4: Close-Up Guardian Remote Connectors (#7 & #11)**



**Table 1-2: Guardian Rear Panel Connectors and Controls**

Reference Number Figure 1-3	Name	Type	Function
1	HV OUTPUT	White Custom Banana	Optional Rear Panel High Voltage Output Terminal
2	DRIVE+	Sealed Terminal	(No Connection)
3	SENSE+	Sealed Terminal	(No Connection)
4	SENSE-	Sealed Terminal	(No Connection)
5	DRIVE-	Black Banana Plug Recep.	Ground Reference for all Tests
6	Voltage Selector	Red 2-position DIP Switches (2) (Refer to Figure 1-6)	Switches for selecting range of AC power source: Set to 100V for 90-100VAC operation Set to 120V for 110-130VAC operation Set to 220V for 200-220VAC operation Set to 240V for 220-250 VAC operation
7	REMOTE	Black 11 screw relay strip (Refer to Figure 1-4)	Remote input signals : START, RESET, COM & INTER LOCK Remote output signals : UNDER TEST, PASS, & FAIL
8	1 Ω CAL	Hole	(No Connection) Calibration for Continuity Test
9	AC Inlet Module	Black 3-prong receptacle and fuse drawer (Refer to Figure 1-6)	Fuse drawer and 3-wire connection for AC power Source. <b>G10kVAC:</b> 6.3A 250V 100-120V operation, 600W Max 3.15A 250V 220-240V operation, 600W Max <b>G12kVDC:</b> 6.3A 250V 100-120V operation, 600W Max 3.15A 250V 220-240V operation, 600W Max <b>G500VA:</b> 15A 250V 100-120V operation, 1500W Max 6.3A 250V 220-240V operation, 1500W Max
10	FAN	Temp Control Fan	To cool unit : ON ≥50°C, OFF <50°C
11	GROUND	Silver banana plug screw	Chassis ground connection
12	REMOTE	Silver 9 pin D-Type Connector (Refer to Figure 1-4)	Remote control connections
13	RS232	Sealed Connection Port	Optional RS232 Interface Connection
14	SCAN	Sealed Connection Port	Optional External Scanner Connection
15	GPIB	Sealed Connection Port	Optional IEEE-488 Interface Connection

## 1.4 Installation

### 1.4.1 Dimensions

The Guardian instrument is supplied in bench configuration ( a cabinet with resilient feet for placement on a table). Flip feet are provided under the front feet so that the unit can be tilted back for convenient operator viewing.

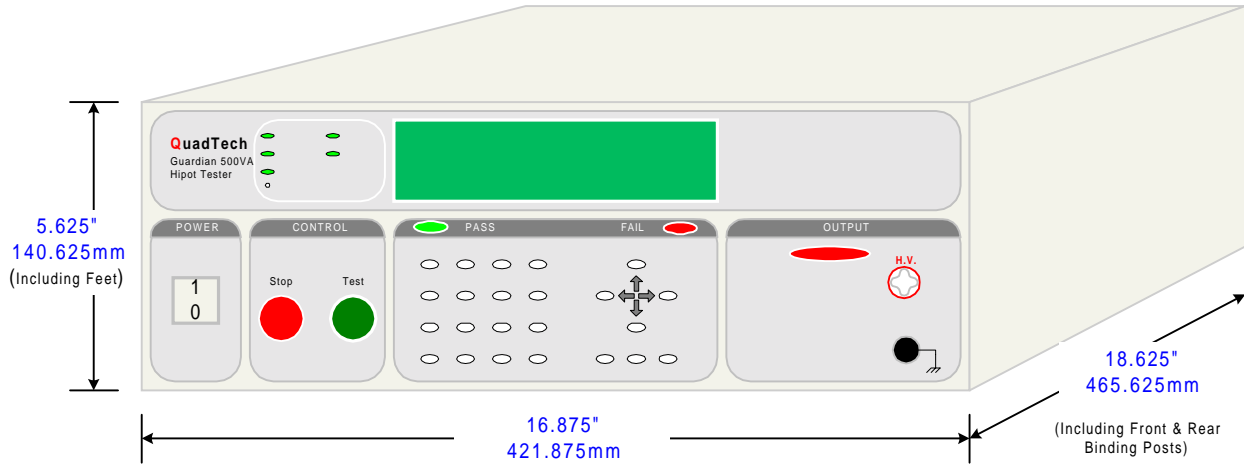

**Figure 1-5 : Guardian 500VA, 10kVAC & 12kVDC Instrument Dimensions**

### 1.4.2 Instrument Positioning

The Guardian 500VA, 10kVAC & 12kVDC instruments contain a digital display for direct readout of the measured parameters. The optimum viewing angle is slightly down and about 10° either side of center. For bench operation the front flip feet should always be used to angle the instrument up. In bench or rack mount applications the instrument should be positioned with consideration for ample air flow around the rear panel fan ventilation hole. An open space of at least 3 inches (75mm) is recommended behind the rear panel.

### 1.4.3 Power Requirements

 The Guardian 500VA, 10kVAC & 12kVDC instruments can be operated from a power source of 90 to 130 VAC or 200 to 250 VAC. Power connection is via the rear panel through a standard receptacle. Before connecting the 3-wire power cord between the unit and AC power source make sure the voltage selection switches on the rear panel and fuse (Figure 1-6) are in accordance with the power source being used. The G10kVAC & G12kVDC units require a 6.3A 250V fuse for 120V operation (3.15A 250V fuse for 220V operation) with a max power rating of 600W. The G500VA unit requires a 15A 250A fuse for 120V operation (6.3A 250V fuse for 220V operation) with a max power rating of 1500W. Always use an outlet that has a properly connected protection ground.

**NOTE:**

If G500VA power output is to exceed 250VA, then the power source must be 220/240V.

## Procedure for Changing A Guardian 500VA, 10kVAC & 12kVDC Fuse

**WARNING**  
**MAKE SURE THE UNIT HAS BEEN DISCONNECTED FROM ITS AC POWER SOURCE FOR AT LEAST 5 MINUTES BEFORE PROCEEDING.**

Remove the fuse drawer, by inserting a flat head screwdriver behind the small tab located just below the 3 prong receptacle, and force outward.

Once the fuse drawer has been removed from the instrument snap the fuse from the holder and replace. Make sure the new fuse is of the proper rating. Note that the fuse drawer can also be used to store a spare fuse.

Install the fuse drawer back into the inlet module (fuse down) by pushing in until it locks securely in place.

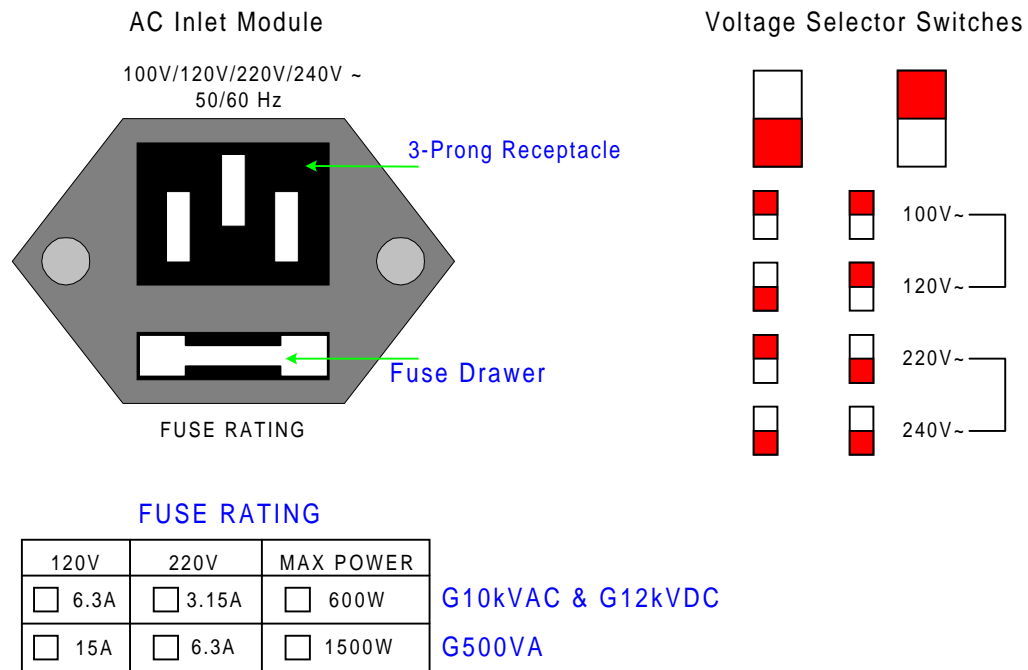

**Figure 1-6 : Guardian 500VA, 10kVAC & 12kVDC Fuse Drawer**

#### 1.4.4 Safety Inspection



Before operating the instrument inspect the power inlet module on the rear of the Guardian unit to ensure that **the properly rated fuse is in place**, otherwise damage to the unit is possible. Refer to paragraph 1.4.3.

The Guardian 500VA, 10kVAC & 12kVDC units are shipped from QuadTech with a standard U.S. power cord, QuadTech P/N 4200-0300(with Belden SPH-386 socket or equivalent and 3-wire plug conforming to IEC 320). Make sure that the instrument is used only with these cables (or approved international cord set) to ensure that the instrument is provided with **connection to protective earth ground**.

The surrounding environment should be free from excessive dust to prevent contamination of electronic circuits. The surrounding environment should also be free from excessive vibration. Do not expose the Guardian unit to direct sunlight, extreme temperature or humidity variations, or corrosive chemicals.

---

## Section 2 : Operation

---

### 2.1 Terms and Conventions

**Table 2-1: Measurement Unit Prefixes**

<u>Multiple</u>	<u>Scientific</u>	<u>Engineering</u>	<u>Symbol</u>
1000000000000000	10 <sup>15</sup>	Peta	P
1000000000000	10 <sup>12</sup>	Tera	T
1000000000	10 <sup>9</sup>	Giga	G
1000000	10 <sup>6</sup>	Mega	M
1000	10 <sup>3</sup>	Kilo	k
.001	10 <sup>-3</sup>	milli	m
.000001	10 <sup>-6</sup>	micro	u
.000000001	10 <sup>-9</sup>	nano	n
.000000000001	10 <sup>-12</sup>	pico	p
.000000000000001	10 <sup>-15</sup>	femto	f

**ARCCing:** Sparking or ‘flashing over’ caused by a breakdown of electrical insulation.

#### Current:

**AC:** Alternating Current. An electric current that has one polarity during part of the cycle and the opposing polarity during the other part of the cycle. Residential electricity is AC.

**DC:** Direct Current. Non-reversing polarity. The movement of charge is in one direction. Used to describe both current and voltage. Batteries supply direct current (DC).

**Charging Current:** An insulated product exhibits the basic characteristics of a capacitor. Application of a voltage across the insulation causes a current to flow as the capacitor charges. This current instantaneously rises to a high value as voltage is applied then exponentially decays to zero as the DUT becomes fully charged. Charging current decays to zero much faster than dielectric absorption.

Dielectric Absorption:	The physical phenomenon in which insulation appears to absorb and retain an electrical charge slowly over time. Apply a voltage to a capacitor for an extended period of time, then quickly discharge it to zero voltage. Leave the capacitor open circuited for a period of time then connect a voltmeter to it and measure the residual voltage. The residual voltage is caused by the dielectric absorption of the capacitor.
Dielectric Strength:	The ratio between the voltage at which breakdown of the insulating material occurs and the distance between the two points subject to the applied voltage.
Dielectric Withstand Test:	This is the most common electrical safety test performed. A high voltage (either AC or DC) is applied to determine if a breakdown will occur in the insulation of the DUT. Dielectric Withstand is also referred to as a hipot (high potential) test.
Discharge:	The act of draining off an electrical charge to ground. Devices that retain charge should be discharged after an IR or DC HiPot test.
DUT:	Device Under Test. The product being tested.
Frequency:	The rate at which current or voltage reverses polarity and then back again completing a full cycle, measured in Hertz (Hz) or cycles/second. AC Line Frequency = 50/60 Hz.
<b>Ground:</b>	
Ground:	The base reference from which voltages are measured, nominally the same potential as the earth. Also the side of a circuit that is at the same potential as the base reference.
Ground Bond Test:	Test to verify that all conductive parts of a product that are exposed to user contact are connected to the power line ground. The ground bond test is similar to the ground continuity test. The main difference is that the ground bond test verifies the integrity of the ground connection using a high current AC signal with current level as high as 30Amps. Ground bond provides a better simulation of how a product will perform under an actual fault condition.
Ground Continuity:	Test to verify that all conductive parts of a product that are exposed to user contact are connected to the power line ground. GC Test normally performed with a low current DC signal that checks to ensure the ground connection has a resistance of $<1\Omega$ .

**Insulation Resistance:** Measures the total resistance between any two points separated by electrical insulation. The IR test determines how effective the dielectric (insulation) is in resisting the flow of electrical current.

#### Interface:

**IEEE-488:** General Purpose Interface Bus (GPIB). An industry standard definition of a Parallel bus connection for the purpose of communicating data between devices.

**RS232:** An industry standard definition for a Serial line communication link or port.

**Scanner:** A electronic device designed to switch or matrix signals.

#### Leakage Current (LC):

**Leakage Current:** The residual flow of current that flows through the insulation after a high voltage has been applied for a period of time. The leakage current is equal to the applied voltage divided by the insulation resistance. Leakage current is the main measured value for AC hipot and DC hipot.

**Applied Part LC Test:** A line leakage current test which measures the current that would flow from or to applied parts and between applied parts such as sensor and patient leads. This test is the most complicated and time consuming line leakage test.

**Earth LC Test:** The most important and most common of the line leakage tests. Earth leakage current is basically the current flowing back through the ground conductor on the power cord. It is measured by opening the ground conductor, inserting a circuit with the simulated impedance of the human body and measuring the voltage across part of the circuit with a true RMS voltmeter.

**Enclosure LC Test:** A line leakage test which measures the current that flows through the human body if the body had touched the enclosure of the DUT.

**Line LC Test:** A line voltage leakage current test simulates the effect of a person touching exposed metal parts of a product and detects whether or not the leakage current that flows through the person's body remains below a safe level. Line leakage tests are conducted by applying power to the product being tested, then measuring the leakage current from any exposed metal on the chassis of the product under various fault conditions such as "no ground". A special circuit is used to simulate the impedance of the human body.

## Limits:

High Limit:	The high limit is the upper value for a test to be considered a pass. If the measured value is higher than the high limit the test is considered a fail. In hipot, leakage current and ground bond modes a high limit is required.
Low Limit:	The low limit is the lower value for a test to be considered a pass. If the measured value is lower than the low limit the test is considered a fail. In insulation resistance mode a low limit is required.
Mode:	The test which is to be performed such as AC Hipot (WAC), DC Hipot (WDC), Insulation Resistance (IR), Ground Bond (GR) or Leakage Current (LC).
RAMPing:	The gradual increase or decrease of voltage or current over a period of time (step).
Step:	The Guardian 500VA can perform up to 99 tests in a sequence. The step number indicates in which order the tests will be performed. For example if step 1 is an AC hipot test, step 2 a DC hipot and step 3 an insulation resistance measurement then when a test is started the Guardian 500VA will perform an AC hipot test followed by a DC hipot then an insulation resistance measurement.



## 2.2 Startup

Check to make sure the Red Voltage Selector Switches on the rear panel agree with the power source available. Depending on the power source the switch positions should be in the up or down positions as shown in Figure 1-6 (AC Inlet Module & Voltage Selector Switches).

**WARNING**  
NEVER TOUCH THE TEST LEADS IN ANY MANNER (this includes insulation on all wires and clips) when the HIGH VOLTAGE IS APPLIED and red **DANGER** LED is ON.  
  
USE ALL PRECAUTIONS NECESSARY TO AVOID TOUCHING THE DEVICE UNDER TEST WHEN THE RED **DANGER** LED IS ON OR FLASHING.

Connect the instrument power cord to the source of proper voltage. **The instrument is to be used only with three wire grounded outlets.**

Power is applied to the Guardian instrument by pressing the beige [POWER] toggle switch on the front panel to ON (1 position). The Guardian unit should have a warm-up time of at least 15 minutes prior to use.

**WARNING**  
DO NOT TURN INSTRUMENT POWER ON OR OFF WITH TEST DEVICES CONNECTED.

### Operation with External Scanner (Guardian 500VA Hipot Tester ONLY)

If the Guardian 500VA instrument is equipped with an external scanner, then the scanner channels must be programmed for an AC hipot, DC hipot, insulation resistance and leakage current test. When an external scanner is connected to the Guardian 500VA instrument, two additional display screens appear during programming. Refer to Figure 2-1. Use the numerical keypad to enter which channel or channels have HV (High) or GROUND (Low) applied during the test. If “disable” is selected, the scanner will not be used. The instruction “Select Scanner Disable” prompts the user to define which of the 8 scanner channels are high or low per scan box. The first external scanner is defined as Scan Box 1. Scan Box 2 is the second external scanner. Scan Box 3 is the third external scanner. Up to 8 external scanners can be added for a total of 64 channels. Refer to paragraph 3.3 for external scanner programming.

High =Disable Scan Box-Channel 1	Low = Disable Scan Box-Channel 1
-------------------------------------	-------------------------------------

**Figure 2-1: Scanner Programming Display**

## 2.3 Programming Hipot Tests

### 2.3.1 Programming an AC Hipot Test (G500VA & G10kVAC units only)

Press [BUTTON]:	G500VA:	G10kVAC:
[PROG]	Select Step = 1 1 - 99 (UP/DOWN)	Select Step = 1 1 - 99 (UP/DOWN)
Select Test Step. Press UP or DOWN arrow key to enter test step.		
[ENTER]	Select Mode = WAC Press (UP/DOWN)	Select Mode = WAC Press (UP/DOWN)
Select Test Mode. Press UP arrow key to display WAC.		
[ENTER]	High = Disable Scan Box - Channel 1	
Select Scanner Disable *. Press Numerical keys to enter HIGH scanner channels.		
[ENTER]	Low = Disable Scan Box - Channel 1	
Select Scanner Disable *. Press Numerical keys to enter LOW scanner channels.		
[ENTER]	Voltage = 0.000kV 0.05 - 5kV	Voltage = 0.000kV 0.1 - 10kV
Select Test Voltage (kV). Press Numerical & Decimal keys to enter Test Voltage.		
[ENTER]	High Limit = 2.500mA 0.001 - 100.0mA	High Limit = 2.500mA 0.001 - 20mA
Select High Limit (mA). Press Numerical & Decimal keys to enter High current limit.		
[ENTER]	Low Limit = 0.100 mA 0 - 100.0mA 0 = Disable	Low Limit = 0.100 mA 0 - 20mA 0 = Disable
Select Low Limit (mA). Press Numerical & Decimal keys to enter Low current limit.		
[ENTER]	ARC Limit = 0.001 mA 1 - 100.0mA 0 = Disable	ARC Limit = 0.001 mA 1 - 20mA 0 = Disable
Select ARC Limit (mA) **. Press Numerical & Decimal keys to enter ARC limit.		
[ENTER]	Test Time = Disable 0 - 999s 0 = Disable	Test Time = Disable 0 - 999s 0 = Disable
Select Test Time (sec). Press Numerical & Decimal keys to enter Test Time.		
[ENTER]	Ramp Time = Disable 0 - 999s 0 = Disable	Ramp Time = Disable 0 - 999s 0 = Disable
Select Ramp Time (sec). Press Numerical & Decimal keys to enter Ramp Time.		
[ENTER]	Select Step = 1 1 - 99 (UP/DOWN)	Select Step = 1 1 - 99 (UP/DOWN)
[PROG]	STEP-01 10.0s 1.200kV WAC 0.500mA	STEP-01 10.0s 1.200kV WAC 0.500mA

\* **Applicable only to 500VA unit and only if an external scanner is installed.**  
Refer to ¶ 2.2 and 3.3

\*\* **Although the ARC detect limit can be programmed down to the 1µA level (depending on instrument), the instrument will only detect (measure) the ARC value at ≥ 1mA.**

### 2.3.2 Programming a DC Hipot Test (G500VA & G12kVDC units only)

Press [BUTTON]:

G500VA:

G12kVDC:

[PROG]

Select Step = 1  
1 - 99 (UP/DOWN)

Select Step = 1  
1 - 99 (UP/DOWN)

Select Test Step. Press UP or DOWN arrow key to enter test step.

[ENTER]

Select Mode = WDC  
Press (UP/DOWN)

Select Mode = WDC  
Press (UP/DOWN)

Select Test Mode. Press UP arrow key to display WDC.

[ENTER]

High = Disable  
Scan Box - Channel 1

Select Scanner Disable \*. Press Numerical keys to enter HIGH scanner channels.

[ENTER]

Low = Disable  
Scan Box - Channel 1

Select Scanner Disable \*. Press Numerical keys to enter LOW scanner channels.

[ENTER]

Voltage = 0.000kV  
0.05 - 6kV

Voltage = 0.000kV  
0.1 - 12kV

Select Test Voltage (kV). Press Numerical & Decimal keys to enter Test Voltage.

[ENTER]

High Limit = 2.500mA  
0.001 - 20mA

High Limit = 2.500mA  
0.001 - 10mA

Select High Limit (mA). Press Numerical & Decimal keys to enter High current limit.

[ENTER]

Low Limit = 0.100 mA  
0 - 20mA 0 = Disable

Low Limit = 0.100 mA  
0 - 10mA 0 = Disable

Select Low Limit (mA). Press Numerical & Decimal keys to enter Low current limit.

[ENTER]

ARC Limit = 0.001 mA  
1 - 20mA 0 = Disable

ARC Limit = 0.001 mA  
1 - 10mA 0 = Disable

Select ARC Limit (mA) \*\*. Press Numerical & Decimal keys to enter ARC limit.

[ENTER]

Test Time = Disable  
0 - 999s 0 = Disable

Test Time = Disable  
0 - 999s 0 = Disable

Select Test Time (sec). Press Numerical & Decimal keys to enter Test Time.

[ENTER]

Ramp Time = Disable  
0 - 999s 0 = Disable

Ramp Time = Disable  
0 - 999s 0 = Disable

Select Ramp Time (sec). Press Numerical & Decimal keys to enter Ramp Time.

[ENTER]

Select Step = 1  
1 - 99 (UP/DOWN)

Select Step = 1  
1 - 99 (UP/DOWN)

[PROG]

STEP-01 10.0s  
1.200kV WDC 0.500mA

STEP-01 10.0s  
1.200kV WDC 0.500mA

\* **Applicable only to 500VA unit and only if an external scanner is installed.  
Refer to ¶ 2.2 and 3.3**

\*\* **Although the ARC detect limit can be programmed down to the 1µA level (depending on instrument), the instrument will only detect (measure) the ARC value at ≥ 1mA.**

## 2.4 Programming an Insulation Resistance Test (G500VA & G12kVDC only)

Press [BUTTON]:

G500VA:

G12kVDC:

[PROG]

Select Step = 1  
1 - 99 (UP/DOWN)

Select Step = 1  
1 - 99 (UP/DOWN)

Select Test Step. Press UP or DOWN arrow key to enter test step.

[ENTER]

Select Mode = IR  
Press (UP/DOWN)

Select Mode = IR  
Press (UP/DOWN)

Select Test Mode. Press UP arrow key to display IR.

[ENTER]

High Limit = Disable  
Scan Box - Channel 1

Select Scanner Disable\*. Press Numerical keys to enter HIGH scanner channels.

[ENTER]

Low Limit = Disable  
Scan Box - Channel 1

Select Scanner Disable\*. Press Numerical keys to enter LOW scanner channels.

[ENTER]

Voltage = 0.000kV  
0.05 - 1kV

Voltage = 0.000kV  
0.05 - 1kV

Select Test Voltage (kV). Press Numerical & Decimal keys to enter Test Voltage.

[ENTER]

Low Limit = 1.0MΩ  
0.1 - 50000 MΩ

Low Limit = 1.0MΩ  
0.1 - 50000 MΩ

Select Low Limit (MΩ). Press Numerical & Decimal keys to enter LOW resistance limit.

[ENTER]

High Limit = Disable  
0 - 50000 MΩ 0 = Disable

High Limit = Disable  
0 - 50000 MΩ 0 = Disable

Select High Limit (MΩ). Press Numerical & Decimal keys to enter HIGH resistance limit.

[ENTER]

Test Time = Disable  
0 - 999s 0 = Disable

Test Time = Disable  
0 - 999s 0 = Disable

Select Test Time (sec). Press Numerical & Decimal keys to enter Test Time.

[ENTER]

Ramp Time = Disable  
0 - 999s 0 = Disable

Ramp Time = Disable  
0 - 999s 0 = Disable

Select Ramp Time (sec). Press Numerical & Decimal keys to enter Ramp Time.

[ENTER]

Select Step = 1  
1 - 99 (UP/DOWN)

Select Step = 1  
1 - 99 (UP/DOWN)

[PROG]

STEP-01 10.0s  
1.000kV IR 0.500mA

STEP-01 10.0s  
1.000kV IR 0.500mA

\* **Applicable only to 500VA unit and only if an external scanner is installed.  
Refer to ¶ 2.2 and 3.3.**

## 2.5 Programming a Pause

PAUSE” is a mode selection that allows a test sequence to be stopped while test leads are changed or other operations performed. A 20-character user programmable message will be displayed on the screen when in PAUSE mode and the test will continue when the [TEST] button is pressed or start initiated via remote I/O. The Under Test relay on the remote I/O can also be cycled during PAUSE if required.

### Instrument Operation in PAUSE Mode:

Up/Down (↑ ↓) arrow can be used to cycle through alphanumeric characters.

Right/Left (⇒ ⇐) arrows go to next or previous character.

Under Test “ON/OFF”:

When ON, the under test relay on remote I/O is closed during Pause mode.

When OFF, the under test relay is open on remote I/O during Pause mode.

During test sequence when a Pause is encountered the tester stops, displays Pause and 20 character message until test button is pressed again or start is initiated via remote I/O.

### PAUSE programming menu:

Press [BUTTON]:

Display Reads:

[PROG]

Select Step = 1  
1 - 99 (UP/DOWN)

Select Test Step

Press UP or DOWN arrow key to enter test step

[ENTER]

Select Mode = PAUSE  
Press (UP/DOWN)

Select Test Mode

Press UP arrow key to display PAUSE

[ENTER]

Pause String =  
1

Select message displayed in Pause Mode

Press Numerical & Decimal keys to enter message

[ENTER]

Under Test = OFF  
Select by UP/DOWN

Select status of Under Test Relay

Press UP or DOWN arrow key to select ON or OFF

[ENTER]

ON = Under Test relay is closed during Pause Mode

OFF = Under Test relay is open during Pause Mode

[PROG]

Exit Programming Mode & return to test mode

## 2.6 Programming A Multi-Step Test

Each test can consist of 1 to 99 steps in sequence, for example, a typical three step test might be an AC hipot test followed by a DC hipot test then an Insulation Resistance test. Each step may be programmed for any available function (WAC, WDC, IR or PAUSE) with programmed test conditions independent from the other step.

To change the test mode proceed as follows:

- Press [STOP]
 

Step-01	1.0s
1.200KV WAC	7.50mA
  
- Press [UP] arrow  
To select/examine steps 2-99
 

Step-02	1.0s
1.500KV WDC	15.00mA

Step-03	1.0s
0.750KV IR	1.0MΩ
  
- Press [DOWN] arrow  
To return to lower steps.
 

Step-01	1.0s
1.200KV WAC	7.50mA
  
- **NOTE** for a SINGLE STEP TEST  
**The test voltage (or current for a ground test) for Step 2 must be set to 0.00. Likewise, for a TWO STEP test the voltage or current for Step 3 must be set to 0.00.**
  
- To change a test mode select the step to be changed (1 to 99) as described above.
- Press [PROG]
 

Select Step = 1
1-99 (UP/DOWN)
  
- Press [UP] arrow key  
To select step to be changed
 

Step-01	1.0s
1.200KV WAC	15.00mA
  
- Press [ENTER]
 

Select Mode = WAC
Press UP/DOWN
  
- REPROGRAM per ¶ 2.3.1 (AC Hipot), 2.3.2 (DC Hipot), 2.4 (IR) or 2.5 (PAUSE).

## 2.7 Memory Management

### 2.7.1 Storing a Single Step Test

To store a single test setup, program the test in accordance with your test specification and paragraphs 2.3.1, 2.3.2, 2.4 or 2.5 of this manual. Follow the procedure illustrated below.

Press [Sto]

Store Memory : _1 1
------------------------

Enter storage location for test setup

Store Memory : 12 -
------------------------

Press [ENTER]

Enter additional numeric name\* for memory location (If desired). Otherwise press [ENTER].

Store Memory : 12 Store ?
------------------------------

Press [ENTER]

Step-01	1.0s
1.200KV WAC	7.50mA

\* **To create an alpha numeric name for a particular memory location:**

- Use the [↑] arrow or [↓] arrow to scroll through numeric characters 0-9 then alpha characters A-Z.
- To select the number or letter you want, press the right arrow [⇒].
- Then choose next number or letter and press the right arrow [⇒] again.
- Up to 11 digits can be used to identify the location name.
- When you are finished naming the location, press [ENTER] to accept name.
- Press [ENTER] to accept store.

## 2.7.2 Storing a Multi-Step Test

To store a multi-step test, program the tests in accordance with your test specification and paragraphs 2.3.1, 2.3.2, 2.4, 2.5 and 2.6 of this manual. An example of an AC/DC/IR test sequence is illustrated below.

Press [PROG]

Select Step 01

Press [ENTER] AC Test per ¶ 2.3.1

\*

\*

\*

continue entering AC test setup

After entering RAMP Time, display reads Select Step = 2

Select Step 02

Press [ENTER] DC Test per ¶ 2.3.2

\*

\*

\*

continue entering DC test setup

After entering RAMP Time, display reads Select Step = 3

Select Step 03

Press [ENTER] IR Test per ¶ 2.4

\*

\*

\*

continue entering IR test setup

After entering RAMP Time, Press [PROG]

Press [Sto]

Store Memory : _1 1
------------------------

Enter storage location

Store Memory : _ 3
--------------------

Press [ENTER]

Store Memory : 3 —
-----------------------

Press [ENTER]

Store Memory : 3 Store ?
-----------------------------

Press [ENTER]

Step – 01      1.0s 1.200KV WAC 7.50mA
---

To verify the storage, press [**Rcl**] once. Enter the storage location. Press [**ENTER**] three times. Use [**UP**] arrow key to view Steps 02 and 03. Use [**DOWN**] arrow key to return to Step 01.



### 2.7.3 Recalling a Test Setup

To recall a test setup:

- Press [**Rcl**] once.
- Enter the storage location.
- Press [**ENTER**] three times.
- Use [**UP**] arrow key to view Steps 02, 03, ...
- Use **DOWN** arrow key to return to Step 01.

### 2.7.4 Deleting a Test Setup

To delete a test step from a test setup:

- Use [**UP**] arrow key (or [**DOWN**] arrow key) to get to that step.
- Press [**Prog**]. (to enter programming mode)
- Press [**Delete**]. (to remove test step)
- Press [**Prog**]. (to exit programming mode)

## 2.8 Instrument Zeroing/Offset

The Guardian 500VA, 10kVAC & 12kVDC instruments provide automatic zeroing/offset for lead or fixture effects. During the zeroing/offset process a correction is made (subtracted out) as the result of lead leakage current and stored in instrument memory to be applied to ongoing measurements. For maximum measurement accuracy it is recommended that the unit be zeroed after power-up, any time the test parameters are changed and any time the test leads or fixture are changed. The offset is saved under setup storage, 1 - 99 setups, and is also saved on a power down and power back up. **The instrument should warm-up for at least 15 minutes before zeroing. REFER TO ¶ 2.9 FOR THE CORRECT CABLE CONNECTION.**

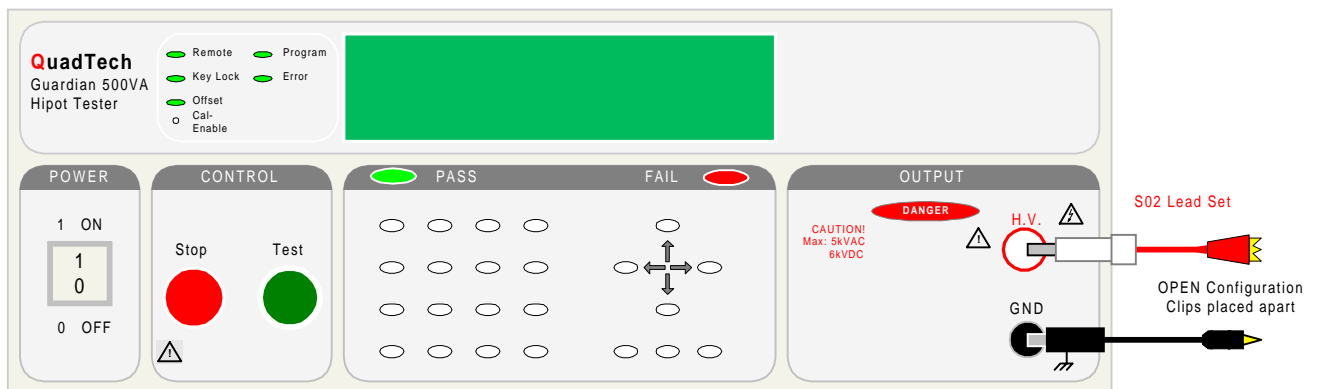

Figure 2-2: Zero/Offset OPEN Configuration

## Offset Continued:

Proceed as follows for automatic zeroing/offset:

- Plug the appropriate cable (or other fixture) into the front panel OUTPUT connectors, **with no device connected**. Refer to paragraph 2.9 for cable configurations based on test to be made. **NOTE:** Test leads for AC Hipot, DC Hipot and IR measurements should be OPEN before performing the OFFSET function.

- Press the [OFFSET] key.

Offset is GET Press Test Key.
----------------------------------

- Press the green [TEST] button.  
Green Offset LED is lit

Step-01 Pass    0.0s 1.200KV WAC 0.038mA
---

- Press the [OFFSET] key.  
Green Offset LED is lit

Offset is ON Press the Offset Key.
---------------------------------------

- Press the [OFFSET] key once.

Offset is OFF Press the Offset Key.
--

- Press the [ENTER] key to accept  
OFFSET ON or OFF

Step-01            1.0s 1.200KV WAC 7.50mA
---

The following formulas apply to the offset function:

For AC offset current < 80µA:

$$\text{Display current} = \sqrt{(\text{current read})^2 - (\text{offset current})^2}$$

For DC offset or AC offset current ≥ 80µA:

$$\text{Display current} = (\text{current read}) - (\text{offset current})$$

## 2.9 Connection to Device Under Test

Before connecting the device for test press the red [STOP] key and make sure the red **DANGER** light is OFF.

Depending on the test to be conducted (AC/DC hipot or Insulation Resistance) connect the test cables to the front panel OUTPUT connectors. Refer to the Figures 2-3 through 2-5 to determine the correct configuration. When using the black cable, with the metal retaining bracket, make sure it is locked behind the connector to prevent this cable from accidentally coming loose.

**WARNING**  
NEVER TOUCH THE TEST LEADS OR THE DEVICE UNDER TEST WHEN THEY ARE CONNECTED TO THE INSTRUMENT AND THE RED **DANGER** LIGHT IS ON OR FLASHING.

### S02 Cable Lead Set

Connect the custom white banana cable to the HV connector on the Guardian instrument and the large red alligator clip to the high side of the device under test. Connect the black banana cable to the GND terminal on the Guardian instrument and the small black alligator clip to the low side of the device under test.

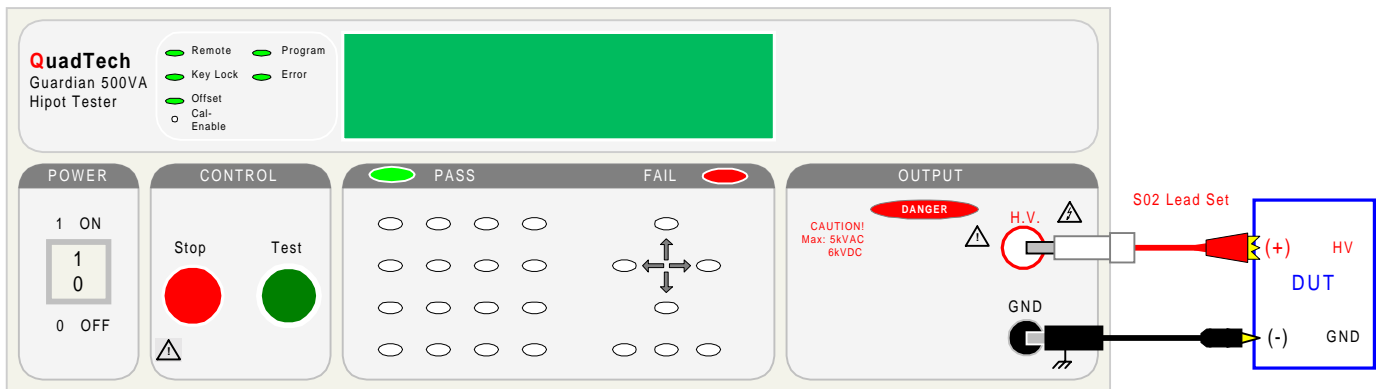

**Figure 2-3: Connection for Hipot/IR Test (Using S02 Cable Lead Set)**

## S07 Power Entry Adapter

The S07 (or G14) Power Entry Adapter Cable allows an AC inlet connection of product to Guardian unit via a three lead set. The leads consist of a white plug for connection to HV output, a black banana plug with retaining bracket for connection to the GND terminal and a black spade lug also for connection to GND. Figure 2-4 illustrates the connection of the S07 Power Entry Adapter Cable to the Guardian 500VA unit.

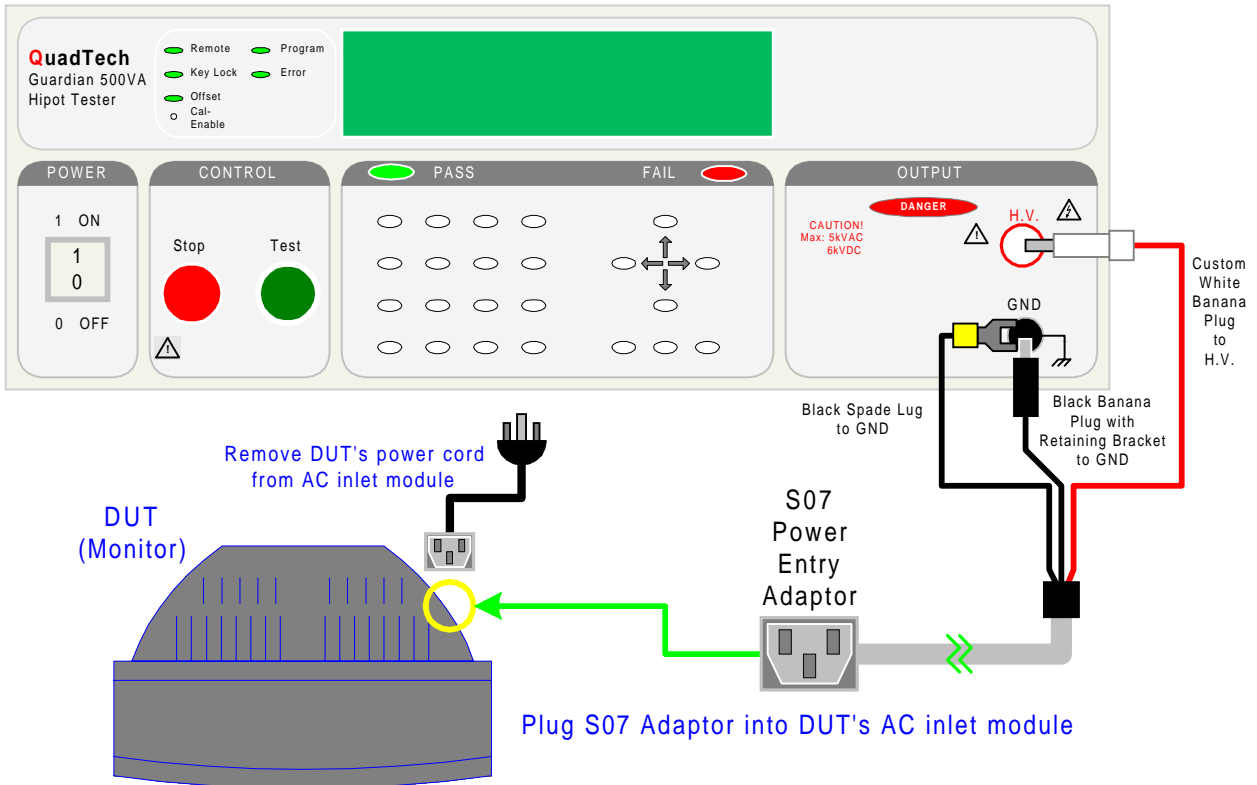

**Figure 2-4: Connection for Hipot/IR Test (Using S07 Power Entry Cable)**



## 2.10 Measurement Procedure

Before a measurement is made, verify the following:

- 1 Guardian instrument power is ON
- 2 15 minute warm-up
- 3 Test parameters programmed
- 4 Test Setup stored
- 5 Offset function selected
- 6 Device Under Test (DUT) connected

The operator has a choice of performing a test at power-up conditions (test conditions at which the instrument was last powered down), or recalling one of 99 possible stored setups. Refer to paragraphs 2.3, 2.4, 2.5 or 2.6 for instructions to change the test mode and/or test conditions.

**To initiate a test at “power-up conditions” proceed as follows:**

- Press [**STOP**]  
Green Offset LED is lit

Step-01	1.0s
1.200KV WAC	7.50mA

- Press [**TEST**]  
Danger LED flashes, Offset LED is lit  
Green PASS LED is lit

Step- 01 Pass	0.0s
1.200KV WAC	0.012mA

- Press [**STOP**]  
Any time to stop test  
Green Offset LED is lit

Step-01	1.0s
1.200KV WAC	7.50mA

### 2.10.1 Viewing Test Results:

To **VIEW** the test results (from a multi-step test):

Press [**RCL**]. The instrument prompts “Memory Location?”

Press [**0**].

Press [**ENTER**].

Then scroll up and down to view the test results.

## 2.11 Initial Parameter Settings

The Guardian 500VA, 10kVAC and 12kVDC instruments have a number of parameter settings that seldom require change, the instrument will power-up with default settings. Each of these parameters are listed in the Table 2-2 and can be changed using the following procedure.

**Table 2-2: Initial Parameter Setting**

Display		Range	Default Value
<b>A General Setting</b>			
	Contrast	1-15	6
	Beep Vol.	ON : 1,2,3 / OFF	3
	Scan No.	1-8	1
	Fail Retest	ON/OFF	OFF
	Print PASS	ON/OFF	OFF
	Print FAIL	ON/OFF	OFF
	Timer U/D	UP/DOWN	DOWN
<b>B Timing Setting</b>			
	Pass Hold	0.2-99.9s	0.5
	Step Hold	ON : 0, 0.1-99.9s	0.2
	Judg. Wait	0.1-99.9s	0.3
	DC Wait	0.0-99.9s	0.0
<b>C Special Setting</b>			
	AC-V Freq.	50-60 Hz	60
	Auto Range	ON/OFF	OFF
	Soft. AGC	ON/OFF	ON
	Password	ON/OFF	OFF
	Lock Recall	ON/OFF	OFF
	Discharge	0.05 – 5.1kV (G500VA & G12kV)	5.1kV
<b>D Remote Setting</b>			
	GPIO Addr.	1-31	3
	Baud Rate	0.3, 1.2, 2.4, 4.8, 9.6, 19.2 kbps	9.6
	GPIO Comp.	ON/OFF	OFF

**NOTE**

The codes for entering Initial Parameter setting mode are different for each instrument. The codes for the G500VA, G10kVAC & G12kVDC units are:

Unit	Code
Guardian 500VA	[ENTER] [5] [0] [0]
Guardian 10kVAC	[ENTER] [1] [0] [0]
Guardian 12kVDC	[ENTER] [1] [2] [0]

**To select initial parameter setting mode:**

Press **ENTER** and then [5] [0] [0].

A. General Setting

Press → (Press numerical keys & ENTER)

1. Contrast = \_ 5  
1-15

Press ↑ (Press OFF Key & ENTER)

2. Beep Vol. = OFF  
Off /1/2/3 (OFF Key)

Press ↑ (Press numerical keys & ENTER)

3. Scan Box NO. = \_ 1  
1-8

Press ↑ (Press OFF Key & ENTER)

4. Fail Retest = OFF  
On/Off (OFF Key)

Press ↑ (Press OFF Key & ENTER)

5. Print PASS = OFF  
On/Off (OFF Key)

Press ↑ (Press OFF Key & ENTER)

6. Print FAIL = OFF  
On/Off (OFF Key)

Press ↑ (Press OFF Key & ENTER)

7. Timer U/D = DOWN  
UP/DOWN (OFF Key)

Press ←

A. General Setting

Press ↑

B. Timing Setting

Press → (Press numerical keys & ENTER)

1. Pass Hold = \_ 0.5s  
0.2 – 99.9s

Press ↑ (Press numerical keys & ENTER)

2. Step Hold = \_ 0.2s  
On, 0.1 – 99.9s

Press ↑ (Press numerical keys & ENTER)

3. Judg. Wait = \_ 0.3s  
0.1 – 99.9s

Press ↑ (Press numerical keys & ENTER)

4. DC Wait = \_ 0.0s  
0.0 – 99.9s



Press ←	B. Timing Setting
Press ↑	C. Special Setting
Press → (Press numerical keys & ENTER) (Does not appear on G12kVDC unit)	1. AC-V Freq. = _ 60Hz 50 - 60 Hz
Press ↑ (Press OFF Key & ENTER)	4. Auto Range = OFF On/Off (OFF Key)
Press ↑ (Press OFF Key & ENTER)	5. Soft. AGC = ON On/Off (OFF Key)
Press ↑ (Press OFF Key & ENTER)	6. Password = OFF On/Off (OFF Key)
Press ↑ (Press OFF Key & ENTER)	11. Lock Rcl = OFF On/Off (OFF Key)
Press ↑ (Press OFF Key & ENTER)	12. Discharge = 5.10 kV 0.50 – 5.1kV
Press ←	C. Special Setting
Press ↑	D. Remote Setting
Press → (Press numerical keys & ENTER)	1. GPIB Addr. = _ 3 1 - 31
Press ↑ (Press numerical keys & ENTER)	2. Baud Rate = 9600 0.3 – 19.2 (OFF Key)
Press ↑ (Press OFF Key & ENTER)	3. GPIB Comp. = ON On/Off (OFF Key)

Illustrated above is the entire scroll through the initial parameter settings. The parameters can be changed singularly. To exit Initial Parameter Setting mode, press [PROG]. The display will return to test set-up.

## 2.11.1 General Settings

In Initial Parameter Setting mode, the Guardian 500VA, 10kVAC and 12kVDC instruments have seven programmable parameters listed under “General Setting”. These parameters are Contrast, Beep Volume, Scan Box Number, Fail Retest, Print PASS, Print FAIL and Timer U/D.

### 2.11.1.1 Contrast

The Contrast of the display is adjustable from 1 – 15. A value of 1 is brightest, a value of 15 is darkest. The default setting for Contrast is 6.

#### NOTE

Contrast can be adjusted at any time the unit is powered up by pressing the left/right arrow key.

If display is totally blank, press the right arrow key to bring the Contrast back.

### 2.11.1.2 Beep Vol.

The volume of the buzzer has four levels of adjustment : OFF, 1, 2 & 3. When OFF is selected the buzzer will not sound. When [1] is selected the buzzer emits a low volume sound. [2] corresponds to a mid level volume and [3] corresponds to a high level volume. The instrument default value is 3 for Beep Volume.

### 2.11.1.3 Scan Box No.

The Scan Box No. setting allows the option of selecting which scan box is being used. The range is 1 – 8 and the default value is 1 (First External Scanner). This function is available on the Guardian 500VA instrument only.

### 2.11.1.4 Fail Retest

The Fail Retest setting allows the option of automatic retest of a device upon fail. The programmable setting is ON or OFF and the default setting is OFF.

### 2.11.1.5 Print PASS

The Print PASS function of the Guardian 500VA, 10kVAC and 12kVDC instruments is used in conjunction with the printer interface. The instrument default value is OFF. When Print PASS is selected ON, the test data will be printed out when a PASS occurs.

### 2.11.1.6 Print FAIL

The Print FAIL function of the Guardian 500VA, 10kVAC and 12kVDC instruments is used in conjunction with the printer interface. The instrument default value is OFF. When Print FAIL is selected ON, the test data will be printed out when a FAIL occurs.

### 2.11.1.7 Timer U/D

Timer U/D controls/changes whether the test time counts down or counts up. The range for Timer U/D is UP or DOWN and the default value is DOWN.

### 2.11.2 Timing Settings

In Initial Parameter Setting mode, the Guardian 500VA, 10kVAC and 12kVDC instruments have three programmable parameters listed under “Timing Setting”. These parameters are Pass Hold, Step Hold, and Judg. Wait.

#### 2.11.2.1 Pass Hold

The Pass Hold setting allows the option of programming a hold time for a PASS buzzer after a single or a multiple step test. The range for Pass Hold is 0.2 – 99.9 sec and the default value is 0.5sec. Refer to Figure 2-6.

#### 2.11.2.2 Step Hold

The Step Hold setting allows the option of programming a hold time between steps. The range for Step Hold is ON, 0.1 – 99.9sec. and the default value is 0.2sec. When Step Hold is ON, the test will stop after each step and display PASS/FAIL for that step. Refer to Figure 2-6.

#### 2.11.2.3 Judg. Wait

The Judgement Wait setting allows the option of programming a hold time on each step. This allows the device to be fully charged prior to a measurement being made and then judged PASS/FAIL. The range for Judgement Wait is 0.1 – 99.9sec and the default value is 0.3sec. Refer to Figure 2-6.

#### 2.11.2.4 DC Wait

DC Wait is for a fixed discharge time (discharge circuit in effect) after the measurement for DC HIPOT ONLY. The range for DC wait is adjustable from 0.0 to 99.9 seconds and the default value is 0.0s. Refer to Figure 2-6.

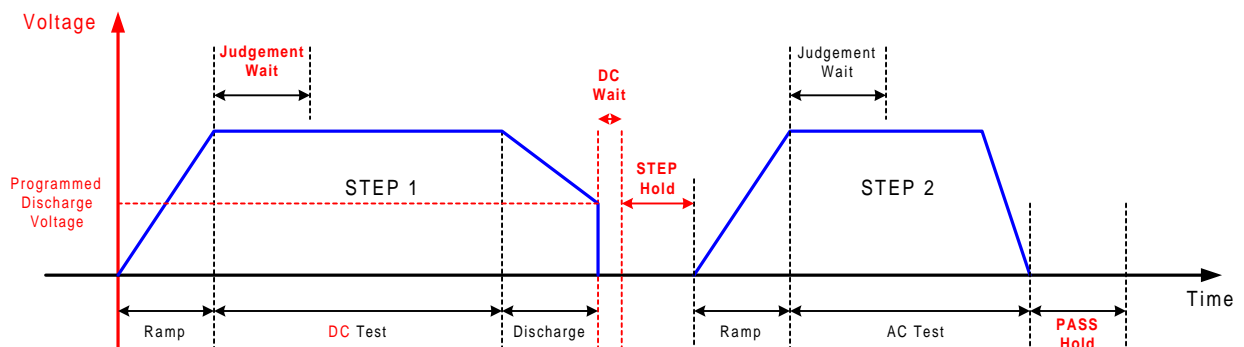

Figure 2-6: Timing Diagram Guardian Hold Settings

### 2.11.3 Special Settings

In Initial Parameter Setting mode, the Guardian 500VA, 10kVAC and 12kVDC instruments have six programmable parameters listed under “Special Setting”. These parameters are AC-V Frequency, Auto Range, Software Automatic Gain Control, Password, Lock Rcl and Discharge.

#### 2.11.3.1 AC-V Freq

The AC V Freq. setting allows the option of programming the frequency for the AC hipot test. The range of AC-V Freq. is 50 – 60Hz and the default value is 60Hz. AC-V Frequency is not applicable to the Guardian 12kVDC instrument.

#### 2.11.3.2 Auto Range

The Auto Range setting allows the option of using the full scale current range (ON) or using the user programmed maximum current limit (OFF). The low current range (3mA full scale) results in increased measurement resolution. The default value of Auto Range is OFF.

#### 2.11.3.3 Soft. AGC

The Software Automatic Gain Control setting allows the option of correcting the output voltage (ON). This is okay when measuring resistors but under special circumstances when measuring large capacitive devices it is best to select Soft. AGC OFF. The default value is ON.

#### 2.11.3.4 Password

The Password setting allows the option of locking out the System Settings, Clear RAM and Key Lock functions when ON is selected. The password can be up to 8 digits using the numerical keys 0 through 9. When a password is entered, the Guardian unit comes back with “CHK : \_” and the password needs to be entered a second time to identify. Pressing the [Dele] key will clear the password just entered. This password will also change the password for front panel lockout.

If the password function has been turned ON and a password entered, then System Settings, Clear RAM and Key lock are de-activated. The override to a password is [ENTER] [8][5][2][4][6][3][1][7][9] [ENTER]. The display will then show the password. Return to System (Special) Settings to disable the password function.

Figure 2-7 illustrates the password setting function. The Guardian 500VA Initial Parameter Entry Code ( [ENTER] [5] [0] [0] ) is used in Figure 2-7. Refer to paragraph 2.11 for Initial Parameter Entry Codes for the G10kVAC and G12kVDC instruments.

## Password Example:

Press [BUTTON]:

[ENTER] [5] [0] [0]

↓ ↓

⇒

↓ ↓ ... ↓

[Off]

[1] [2] [3] (Example Password)

[ENTER]

[1] [2] [3] [ENTER]

[PROG]

Turn instrument OFF. Turn instrument ON again.

[ENTER] [5] [0] [0] DOES **NOT** BRING UP SYSTEM SETTINGS!

Use PASSWORD OVERRIDE to display current password.

[ENTER] [8] [5] [2] [4] [6] [3] [1] [7] [9] [ENTER]

[ENTER] [1] [2] [3] (Enables System Settings)

[CLEAR] [1] [2] [3] [CLEAR] (Enables Clear RAM)

[1] [2] [3] [Off] (Enables Key Lock)

Display Reads:

A. General Setting

C. Special Setting

1. AC-V Freq = \_ 60Hz  
50 - 60Hz

6. Password = OFF  
On/Off (OFF Key)

S/N: \_\_

S/N: \* \* \* \_

S/N: \* \* \* \_  
CHK: \_

6. Password = ON  
On/Off (OFF Key)

Step-01 0.0s  
1.000kV WAC 1.0MΩ

S/N: 123

A. General Setting

Clear Memory?  
ENTER = Yes

Step-01 0.0s  
1.000kV WAC 1.0MΩ

**Figure 2-7: Setting a Password**

### 2.11.3.5 Lock Recall

“Lock Rcl” is used to lockout the ability to recall stored information. The range for Lock Rcl is ON or OFF and the default value is OFF. When the front panel is locked using the “Key Lock” function (§2.11) memory locations may or may not be recalled. If Lock Rcl is ON, memory locations can not be recalled when “Key Lock” is ON. When Lock Rcl is OFF, memory locations can be recalled.

### 2.11.3.6 Discharge

The Discharge function permits the user to set the value of the voltage that the G500VA or G12kVDC instrument will discharge to upon completion of a hipot test. The range is 0.05kV to 5.10kV and the instrument default value is 5.10kV. The time it will take to discharge to a specific voltage is dependent on the capacitance of the DUT. The Discharge time is a natural log function.

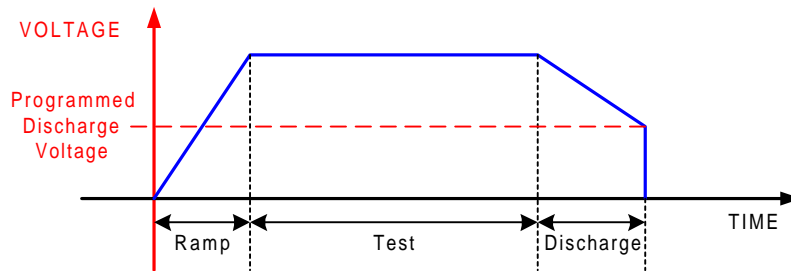

Figure 2-8: Discharge

### 2.11.4 Remote Settings

In Initial Parameter Setting Mode, the Guardian 500VA, 10kVAC and 12kVDC instruments have three programmable parameters listed under “Remote Setting”. These parameters are GPIB Address, Baud Rate and GPIB Compatibility.

#### 2.11.4.1 GPIB Addr.

The GPIB Addr. setting allows the option of programming the GPIB (IEEE-488) address. The range is 1 – 31 and the instrument default value is 3.

#### 2.11.4.2 Baud Rate

The Baud Rate setting allows the option of selecting the Baud Rate in kbps. The range is 0.3, 1.2, 2.4, 4.8, 9.6, and 19.2 kbps. The instrument default value is 9.6 kbps.

#### 2.11.4.3 GPIB Comp.

“GPIB Comp” is the compatibility function of the G500VA, 10kVAC and 12kVDC units. “GPIB Comp” can be selected ON or OFF. The instrument default value is OFF. When selected ON the Guardian 500VA, 10kVAC and 12kVDC GPIB data output is compatible with the Guardian 5000 GPIB data output.

## 2.12 Front Panel Lockout

With front panel lock in effect the ability to change test conditions is prohibited. Only the [TEST] and [STOP] buttons and the setup recall function ([Rcl]) are functional.

Front Panel Lockout Codes	
Unit	Code
Guardian 500VA	[5] [0] [0] [Off]
Guardian 10kVAC	[1] [0] [0] [Off]
Guardian 12kVDC	[1] [2] [0] [Off]

### To activate the front panel lockout:

- With the instrument in standby status ([STOP] button previously pressed and no lights flashing) enter the Front Panel Lockout Code using the data entry keys. The green KEY LOCK indicator light will illuminate indicating the instrument is in the lockout state. The display shows the test set-up.

### To deactivate the front panel lockout:

- With the instrument in standby status ([STOP] button previously pressed and no lights flashing) enter the Front Panel Lockout Code using the data entry keys. The green KEY LOCK indicator light will go out indicating the instrument is no longer in the lockout state. The display shows the test set-up.

#### NOTE

Code for lockout will change if password has been entered (¶ 2.11.3.4)

## 2.13 Software Version Display

The version of software, installed in the instrument, can be displayed on the front panel.

### To display software version:

- Press [POWER] switch to ON (1) and **immediately** press the [ENTER] key.

Guardian 500VA Date : 04/10/2000
-------------------------------------

GPIB Address : 03 Baud Rate : 9600
---------------------------------------

- The display is held for just a few seconds and then reverts to the test set-up display.

## 2.14 Clear Setup Memory

All stored test conditions in instrument memory (99 setups) can be cleared with a few key strokes.

Clear Memory Codes	
Unit	Code
Guardian 500VA	[Clear] [5] [0] [0] [Clear]
Guardian 10kVAC	[Clear] [1] [0] [0] [Clear]
Guardian 12kVDC	[Clear] [1] [2] [0] [Clear]

### To clear setup memory:

- With the instrument in standby status ([STOP] button previously pressed and no lights flashing) enter the Clear Memory Code using the data entry keys.

Clear Memory ?  
ENTER = Yes

- Press [ENTER]

Guardian 500VA  
Date : 04/10/2000

GPIB Address : 03  
 Baud Rate : 9600

- The Beeper sounds loud (to alert that memory has been cleared) and all LED's flash once. The display is held for just a few seconds and then reverts to the test set-up display.
- The Beeper will remain ON until it is turned OFF by entering Initial Parameter Setting mode [ENTER 500], selecting [A. General Setting], [2. Beep Vol. = OFF] and pressing [ENTER]. Remember to press [PROG] to exit Initial Parameter Setting and return to test set-up display.



---

## Section 3 : Interface

---

### 3.1 Remote

A 9 pin D-series remote control connector is located on the rear panel of the Guardian instrument. There is a black 11 screw relay strip for the remote output signals : UNDER TEST, PASS & FAIL and input connections : START, RESET, COM & INTER LOCK.

Inputs require a contact closure and outputs provide a contact closure, as illustrated in Figure 3-1.

Before connecting the instrument to its power source the **interlock function** on the rear panel remote connector must be properly utilized. **This is an important safety feature for the protection of the operator.** Turn on of the instrument's high voltage is inhibited with no interlock connection and is functional with the interlock jumper in place (as shipped from the factory).

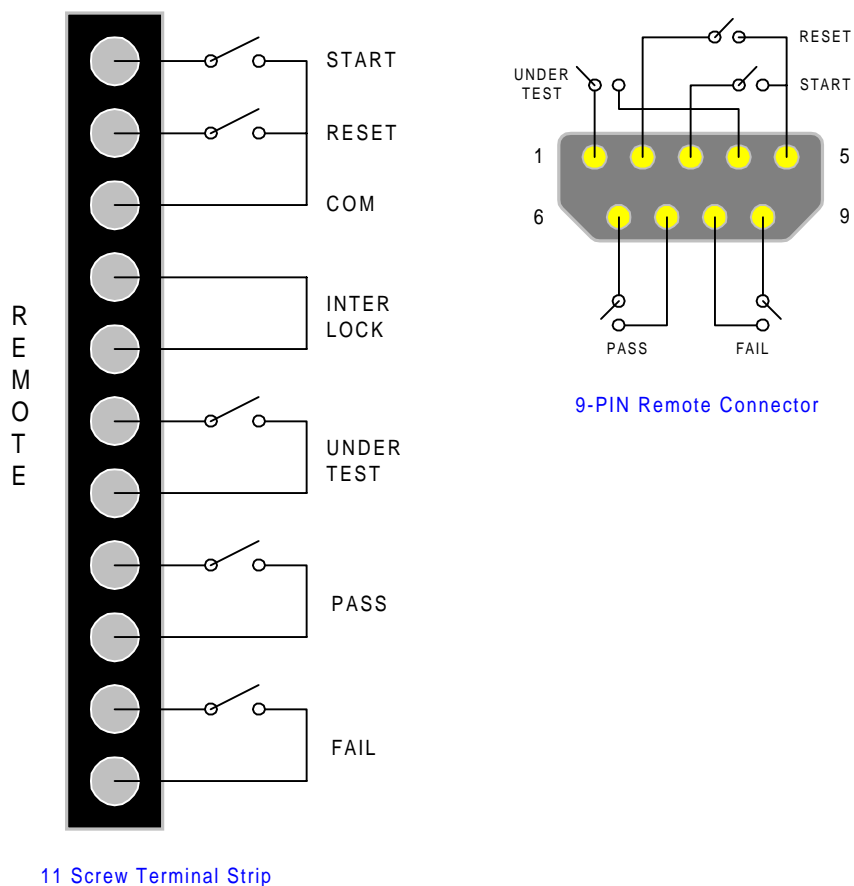

**Figure 3-1: Remote Control Connector**

The G500VA, 10kVAC and 12kVDC instruments have three output signals on the rear panel. The UNDER TEST output terminal is short during TEST as the relay contacts connect to the device powered by 115VAC and current < 0.3A. The PASS output terminal is short when the DUT is judged GOOD. The FAIL output terminal is short when the DUT is judged NO-GOOD.

Figures 3-2 and 3-3 illustrate possible remote control connections. Use extreme care when using a remote control connection as the High Voltage Output is being turned ON and OFF with with an external signal.

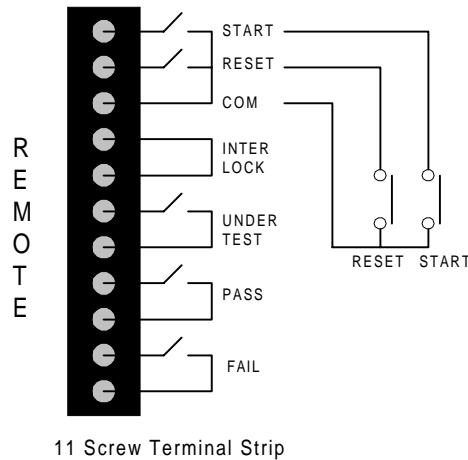

**Figure 3-2: Single Control of TEST or STOP**

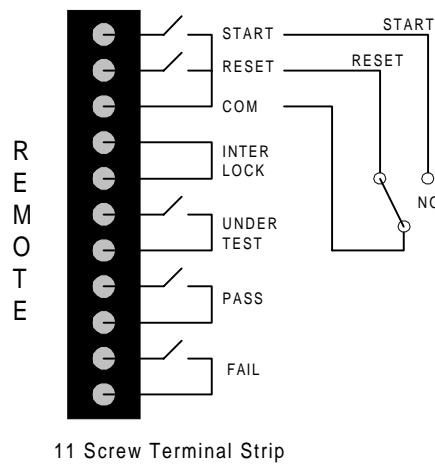

**Figure 3-3: Continuous Control of STOP**

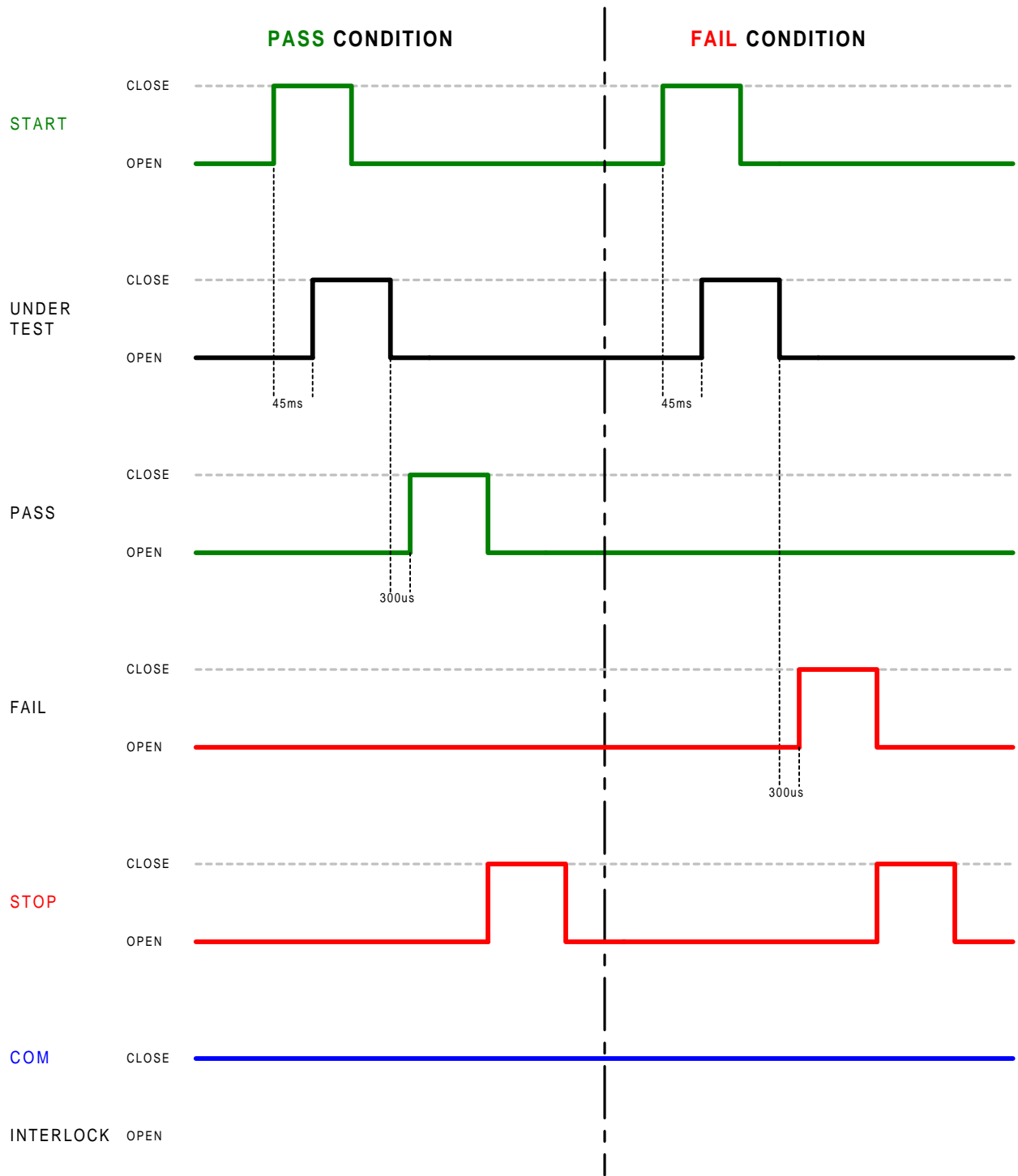
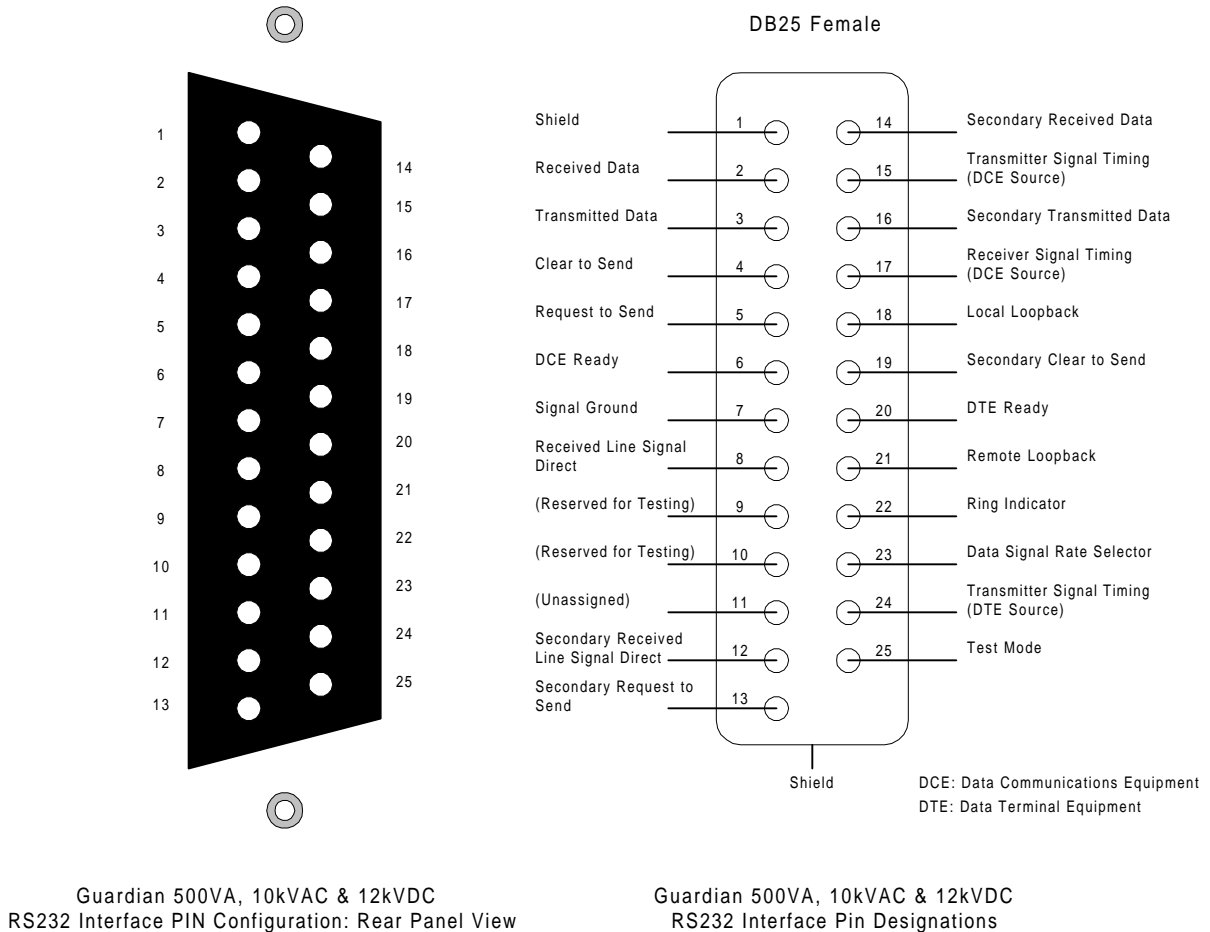

**Figure 3-4: Guardian Instrument Timing Diagram**

## 3.2 RS232 Interface

### 3.2.1 PIN Configuration

An optional RS232 interface is available for the Guardian 500VA, 10kVAC and 12kVDC instruments. The interface is factory installed when the instrument is ordered. The black 25-PIN RS232 connector is located on the rear panel of the Guardian instrument. Figure 3-5 illustrates the RS232 PIN configuration.



**Figure 3-5: RS232 PIN Configuration**

### 3.2.2 RS232 Specifications

Data bits: 8  
Stop bits: 1  
Parity: None  
Baud Rate: 0.3/1.2/2.4/4.8/9.6/19.2 (k) Software Selectable  
EOS: CR + LF  
Echo: Off

#### Selecting Baud Rate

Setting the baud rate is done in the initial parameter settings, ¶ 2.10.4.2. Select the initial parameter Remote Settings, then select Baud Rate.

Parameter	Function	Range	Default Value
Baud Rate	Select Baud Rate	0.3 to 19.2	9.6(kbps)

Use the numerical keys to select baud rate then press [ENTER]. Press [PROG] key to exit initial parameter settings.

### 3.2.3 RS232 Commands

The command set for the RS232 interface is the same as the IEEE-488 interface command set listed in paragraphs 3.3.3 through 3.3.5 of this Instruction Manual.

**NOTE**

CR + LF is the end code for the RS232 Commands.

### 3.2.4 Sample QuickBasic Program

```
CLS
REM
OPEN "com2:9600,n,8,1,rs" FOR RANDOM AS #2:

PRINT #2, "*idn?"      'get unit identification
FOR j = 1 TO 2000: NEXT j

'determine number of bytes at com port
DO WHILE (LOC(2) = 0)
FOR j = 1 TO 2000: NEXT j
LOOP
'then get the rest of the string
Y = X + LOC(2)
DO WHILE (X <> Y)
Y = X
FOR j = 1 TO 2000: NEXT j
X = LOC(2)
LOOP

'read information at com port
R$ = INPUT$(X, #2)

'print identification to screen
PRINT R$

CLOSE #2
END
```

### 3.3 IEEE-488 Interface

#### 3.3.1 PIN Configuration

An optional IEEE-488 interface is available for the Guardian 500VA, 10kVAC and 12kVDC instruments. The interface is factory installed when the unit is ordered. Connection through a blue 24 pin connector (labeled GPIB) on the rear panel. This interface can be used to interconnect a system containing a number of instruments and a controller in which each meets IEEE Standard 488.2 (Standard Digital Interface for Programmable Instrumentation). Figure 3-6 illustrates the PIN Configuration of the IEEE-488 interface.

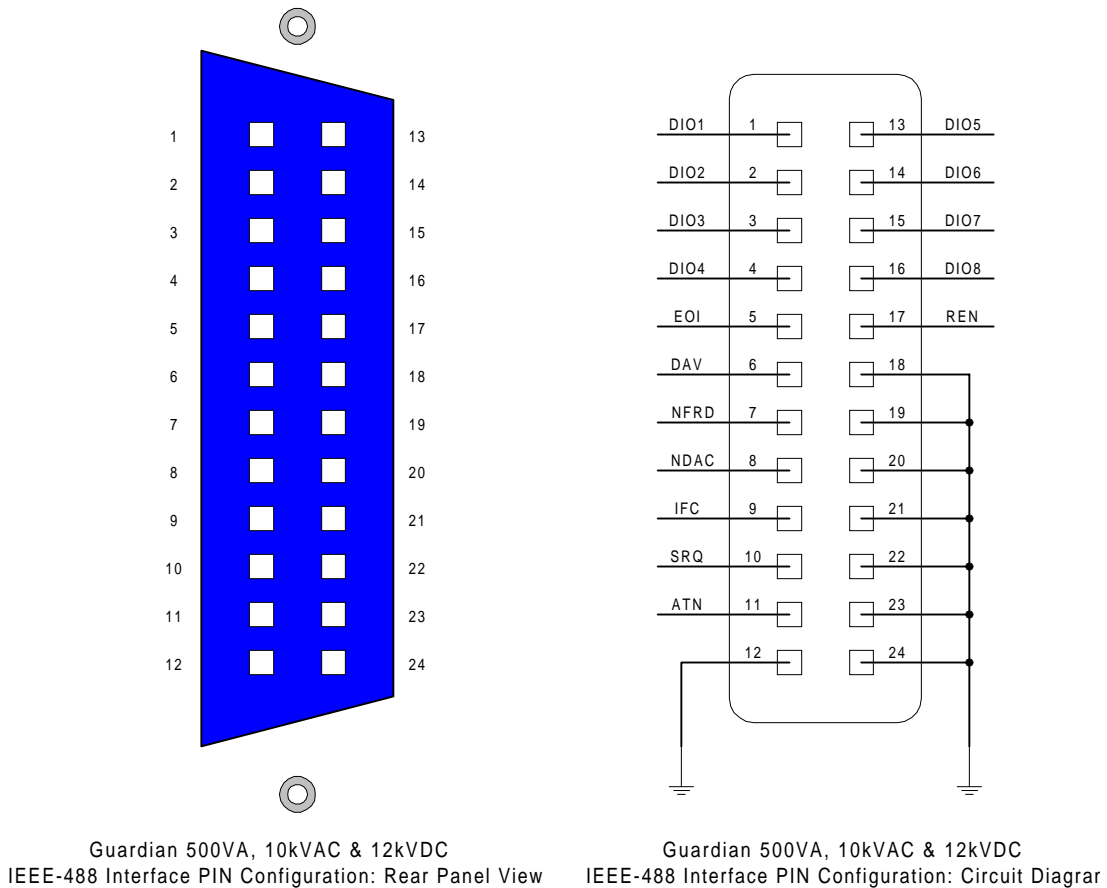

**Figure 3-6: PIN Configuration IEEE-488 Interface**

### 3.3.2 IEEE-488 Interface Codes and Messages

The IEEE-488 (GPIB) address is defined in the Initial Parameter Setting mode by selecting [Remote Setting] and [GPIB address]. Refer to paragraph 2.10.4.

The Guardian unit is in a remote control status when the REMOTE LED is ON.

To switch to Local from Remote press the [PROG] key, disabled by LLO message.

The only controls functional under Remote operation is [PROG], which switches to Local and [STOP] which resets the unit.

Table 3-1 defines the IEEE-488 Interface codes and their function. Table 3-2 defines the IEEE-488 interface messages and their function.

**Table 3-1 : IEEE-488 Interface Codes**

Code	Function
SH1	Source Handshake
AH1	Acceptor Handshake
T4	Basic Talker Function
L4	Basic Listener Function
SR0	No Service Request Function
RL1	All Remote/Local Function
PP0	No Parallel Poll Function
DC1	All Device Clear Function
DT0	Device Trigger Function
C0	No Controller Functions

**Table 3-2 : IEEE-488 Interface Messages**

Interface Message	Function	Description
GET	Ground Execute Trigger	Response depends on the *DDT, setting to TEST or STOP
GTL	Go To Local	Switch unit to local
SDC	Selected Device Clear	Reset the unit
LLO	Local Lockout	Disables [PROG] switch to local
IFC	Interface Clear	Reset bus interface



### 3.3.3 IEEE-488 Interface Commands

The IEEE-488 interface function is controlled by ASCII commands which include:

{[command + parameter] ; [command + parameter] + ending code}

The length of the string is 128 characters. It is not necessary to input any sign or space between the command and parameter. Any two commands can be connected by "," and [Ending Code]. Ending Code can be any type in Table 3-3.

**Table 3-3 : IEEE-488 Interface Ending Codes**

Ending Code
LF
CR + LF
EOI
LF + EOI
CR + LF + EOI

**NOTE**

The data can be sent out by the IEEE-488 interface to achieve transfer function. The data command is {string message + ending code}. The ending codes are listed in Table 3-3.

**NOTE**

CR + LF is the ending code for the RS232 Commands.

### 3.3.4 Listener Functions

Table 3-4 contains the IEEE-488/RS232 Interface command list. This commands are described on the following pages in order of item number.

**Table 3-4 : Command List**

Item	Command	Parameter	Function
1	STOP	x	stop test
2	TEST	x	start test
3	SHOW (?)	{c}	set testing value
4	STEP (?)	{n}	set Step
5	MODE (?)	{n   c}	set test mode
6	SOUR (?)	{f}	set output voltage or current
7	VOLT (?)	{f}	set output voltage
8	CURR (?)	{f}	set output current
9	HILI (?)	{f   *}	set High Limit
10	LOLI (?)	{f   *}	set Low Limit
11	SARC (?)	{f   *}	set ARC
12	BOXN (?)	{n}	Set Box number
13	HICH (?)	{n   *}	set High Channel
14	LOCH (?)	{n   *}	set Low Channel
15	TIME (?)	{f   *}	set the test time
16	RAMP (?)	{f   *}	set the voltage rise time
17	OFST (?)	{c}	set offset
18	*SAV	{n}	save the setting value
19	*RCL	{n}	read the setting value
20	CLER	x	clear the memory
21	*IDN (?)	x	check the unit number
22	*DDT (?)	{n   c}	set the response to Trigger
23	*TRG	x	execute Trigger command
24	*RST	x	reset the unit
25	DEV(?)	{n}	selects LC Device
26	LINE(?)	{n}	selects LC Line Input
27	POWER(?)	{n}	selects LC Power
28	PWHI(?)	{f   *}	set Power High Limit
29	PWLO(?)	{f   *}	set Power Low Limit

**Where**

- x: no parameter required
- n: indicates integer
- f: indicates floating
- c: indicates memory mark
- \*: indicates the "\*" character of ASCII

## 1. STOP

Stop testing, same as STOP on front panel.

## 2. TEST

Start testing, same as START on front panel.

## 3. SHOW (?) {c}

Set and check the testing value, [STATUS] [STEP] [MODE] [SOURCE] [MEASURE] [TIMER] [CHAN] [SAVE]

The command can connect each parameter with "|". Each parameter can be abbreviated. Ex: STA=STATUS, STE=STEP, SO=SOURCE, SA=SAVE

A delay  $\geq$  150 msec should be used between commands during measurements.

## 4. STEP (?) {n}

Set step number (1 - 99). Set step number first before setting test conditions for that step.

## 5. MODE (?) {n | c}

Set test mode by number or memory sign.

<u>Mode</u>	<u>Number</u>	<u>Memory Sign</u>
AC Hipot	1	A or WA
DC Hipot	2	D or WD
Insulation Resistance	3	I or IR
Pause	5	P or PS

If testing mode is changed the test conditions will be cleared to the initial value.

Pause Mode:

PSTR(?) {string}

{string} maximum of 20 characters and <spaces> are not valid.

Under Test Signal:

PUTS (?) <0 or 1>" and "PUTS?"

0 = Off, 1 = On

## 6. SOUR (?) {f}

Set the output voltage of current according to mode selected.

<u>Mode</u>	<u>SOURCE Output</u>
AC Hipot	f = 0.01 - 5.0 KV
DC Hipot	f = 0.01 - 6.0 KV
Insulation Resistance	f = 50 - 1000 V

The output voltage for current can be set by SOUR or VOLT or CURR directly.

**VOLT or CURR is the recommended method to avoid improper setting**

(5 Amp could be interchanged for 5 KV, depending on the MODE selected).

## 7. VOLT (?) {f}

Set the output voltage (similar to SOUR).

## 8. HILI (?) {f | \*}

Set the high limit value according to mode selected. \* disables the high limit.

<u>Mode</u>	<u>High Limit</u>
AC Hipot	f = 0.01 - 40.00 mA
DC Hipot	f = 0.01 - 20.00 mA
Insulation Resistance	f = 1 - 9999 MΩ

In Hipot mode if the High Limit is smaller than the Low Limit, the low limit is disabled.  
In IR mode the value can not be smaller than the Low Limit, otherwise error 2 is indicated.

## 9. LOLI (?) {f | \*}

Set the low limit value according to mode selected. \* disables the low limit.

<u>Mode</u>	<u>Low Limit</u>
AC Hipot	f = 0.01 - 40.00 mA
DC Hipot	f = 0.01 - 20.00 mA
Insulation Resistance	f = 1 - 9999 MΩ

In Hipot mode the low limit is disabled if greater than High Limit.  
In IR mode the low limit is disabled if greater than the High Limit.

## 10. SARC (?) {f | \*}

Set the arc limit value. \* disables the limit.

<u>Mode</u>	<u>Arc Limit</u>
AC Hipot	f = 0.1 - 40.00 mA
DC Hipot	f = 0.1 - 20.00 mA

## 11. BOXN (?) {n}

Select scan box.

n : 1 – x, x is determined by number preset in initial parameter setting (¶ 2.11).

If more than one scan box is being used, use this command to select the scan box before the high and low channels are set.

## 12. HICH (?) {n | \*}

Set the High Channel, n : 1 - 8. \* disables the limit.

More than one channel is possible (Ex: HICH 1| 3| 5).

**13. LOCH (?) {n | \*}**

Set the Low Channel, n : 1 - 8. \* disables the limit.  
More than one channel is possible (Ex: LOCH 1| 3| 5).

**14. TIME (?) {f | \*}**

Set the Test Time, f : 0.1 - 999 sec. \* disables the timer.  
If the disable timer is set to TEST ON, the unit will remain in TEST ON status.

**15. RAMP (?) {f | \*}**

Set the voltage rise time, f : 0 - 99.9 sec. \* disables the timer.

**16. OFST (?) {c}**

Set or examine the offset value.  
C : is a word character or abbreviation  
“GET” : set a scratch status. “OFF” : close the offset function  
“STOP” command makes “OFST GET” = “OFST OFF”.

**17. \*SAV {n}**

Save the test conditions for later recall (up to 99 steps each) in memory location  
n : 1 - 99.

**18. \*RCL (?) {n}**

Recall the test conditions that have been saved (up to 99 steps each) in memory  
location, n : 1 - 99.

**19. CLER**

Resets the instrument from interface control.  
All data is erased except the GPIB address and the RS232 Baud Rate.

**20. \*IDN ?**

Checks the instrument for identification (unit number).  
The unit number is displayed after entering the command “QuadTech Guardian  
500” (or Guardian 100 or Guardian 120 depending on instrument).

**21. \*DDT (?) {n | c}**

Determines the response from the interface when the instrument receives TRG or  
GET command.

“0” or “S”	Stop testing
“1” or “T”	Start testing
“2” or “NS”	Stops testing after receiving “*TRG” or “GET” command and “*DDT” will change to “NT”.
“3” or “NT”	Starts testing after receiving “*TRG” or “GET” command and “*DDT” will change to “NS”.

**22. \*TRG**

Triggers the instrument and functions the same as interface message GET.  
This is dependent on the setting of DDT, see 21 above.

**23. \*RST**

Resets the instrument and functions the same as interface message SDC.







### Example: How to Display saved results (#8 SAVE)

Write : "SHOW Step|save"

Read : STEP 1

Read : STEP 1

Write : "SHOW mode"

Read : MODE 1

Read : STEP 1 shows step by pressing "SHOW step|save"  
"SAVE" parameter can not be used alone

SHOW SAVE will display Error 2

If the instrument is required to display saved item, just use "SHOW?" command

If the instrument is required to display more than one testing value, no matter what

the order of parameters, the output will display the following.

[STATUS], [STEP],[MODE],[SOURCE],[MESSAGE],[TIMER],[CHAN]

Any two parameters are separated by a ","

Example: Write: "SHOW STEP|STATUS|MODE"

Read: STATUS 2, STEP 1, MODE 1

The string length sent by SHOW may not be more than 107 bytes (including ending code)

### 3.3.6 Sample QuickBASIC Program

```
REM $INCLUDE: 'qbdecl.bas'
'declarations
ADAP$ = "GPIB0": G500$ = "DEV3": V% = 1
W% = 0: C$ = SPACE$(50): d$ = SPACE$(50): C1$ = SPACE$(50): D1$ =
SPACE$(50)
STAT$ = SPACE$(50)

'find IEEE card and G500
CALL IBFIND(ADAP$, GPIB0%)
CALL IBFIND(G500$, G500%)

CLS 'clear screen

'read identification from g500
CALL IBWRT(G500%, "*IDN")
CALL IBRD(G500%, D1$)
PRINT D1$

'open a file to store data and status to
20
PRINT "FILE NAME TO STORE RESULT (less than 8 characters)"
INPUT NAMES$
IF LEN(NAMES$) = 0 THEN NAMES$ = "DATA"
IF LEN(NAMES$) > 8 THEN GOTO 20
NAMES$ = NAMES$ + ".TXT"
OPEN NAMES$ FOR APPEND AS #1

'ask user for mode, voltage, current, ramp and test time
50
PRINT "MODE 1 = AC, 2 = DC"
INPUT MODE$
IF MODE$ = "" OR MODE$ > "2" OR MODE$ < "1" THEN GOTO 50 'check mode is
AC/DC hipot
100
PRINT "INPUT VOLTAGE IN kV"
INPUT VOLT$
IF VOLT$ = "" OR VOLT$ > "5" THEN GOTO 100 'check voltage is in range
200
PRINT "HIGH CURRENT LIMIT IN mA"
INPUT CURR$
IF CURR$ = "" OR CURR$ > "40" THEN GOTO 200 'check current is in range
PRINT "RAMP TIME IN seconds"
INPUT RAMP$
```

```

300
PRINT "TEST TIME IN seconds"
INPUT TIM$
IF TIM$ = "" OR TIM$ > "999.9" THEN GOTO 300 'check time is in range

'configure g500
SET$ = "STEP1;MODE" + MODE$ + ";SOUR " + VOLT$ + ";HILI" + CURR$ +
";RAMP" + RAMP$ + ";TIME" + TIM$
CALL IBWRT(G500%, SET$)          'send string to g500
REM CALL IBRD(G500%, C$)        'read status of g500

'perform a measurement
CALL IBWRT(G500%, "STOP") 'make sure unit is in stop mode
CALL IBRD(G500%, C$)      'read status
PRINT C$
CALL IBWRT(G500%, "TEST") 'start measurement
FOR I = 1 TO 500
NEXT I
CALL IBWRT(G500%, "SHOW STATUS") 'check status of unit
CALL IBRD(G500%, STAT$)
WHILE VAL(MID$(STAT$, 8, 1)) = 1 'loop while status is testing
    CALL IBWRT(G500%, "SHOW STATUS")
    CALL IBRD(G500%, STAT$)
    PRINT STAT$
WEND

'get data from G500
CALL IBWRT(G500%, "SHOW SOURCE|MEASURE") 'ask for voltage and current
levels
CALL IBRD(G500%, d$) 'read current and voltage levels
PRINT "DATA IS: "; d$ 'output data to the screen
PRINT #1, d$ + STAT$ + TIME$ + " " + DATE$ 'store data and status to open file
CLOSE #1

END

```

### 3.4 Printer Interface

An optional Printer Interface is available for the Guardian 500VA, 10kVAC and 12kVDC instruments. The Printer interface takes the place of the IEEE-488 Interface and is factory installed when the unit is ordered. Connection is through a black 25-PIN connector in the slot labelled 'GPIB' on the rear panel of the Guardian unit. Figure 3-7 illustrates the Printer PIN Configuration.

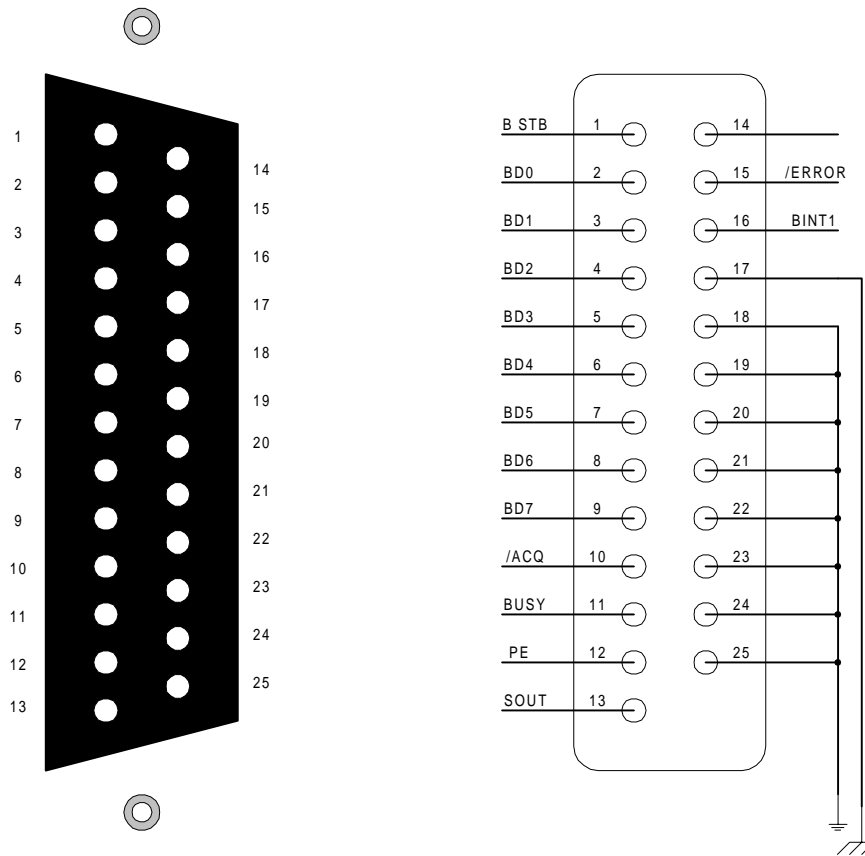

Guardian 500VA, 10kVAC & 12kVDC  
PRINTER Interface PIN Configuration: Rear Panel View

Guardian 500VA, 10kVAC & 12kVDC  
PRINTER Interface PIN Configuration: Circuit Diagram

**Figure 3-7: Printer PIN Configuration**

### 3.5 Scanner Interface

An optional Scanner Interface is available for the Guardian 500VA instrument only. The Scanner interface is factory installed when the unit is ordered. Connection is through the black 25-PIN connector labelled ‘SCAN’ on the rear panel of the Guardian 500VA unit.

#### 3.5.1 Scanner Accessories

The Guardian 500VA instrument may be used with a scan unit for multi-point hipot and insulation resistance tests. Table 3-7 displays the scanner accessories available for the G500VA unit.

**Table 3-7 : Guardian 500VA Scanner Accessories**

Accessory	Qty	QuadTech P/N
25 pin interconnect cable (G500VA to Scanner)	1	G17
Hipot Test Lead Set (G500VA to Scanner I/P)		
HV plug to sheathed banana plug (red)	1	G18
Banana Plug (with retaining bracket) to sheathed banana plug (black)	1	G19
Hipot Scan Clip Leads (Scanner to front panel outputs of DUT)		
Sheathed banana plug (orange) to alligator clip (red)	8	G21
Scan Card for Guardian 500VA AC/DC/IR Tester	1	

#### 3.5.2 Scanner Card Installation

The SCAN card is factory installed when the Guardian 500VA instrument is initially ordered. If however, the SCAN card is ordered after the initial buy, install the SCAN card as follows:

1. Remove 4 side panel screws and slide off top cover assembly.
2. Remove 2 rear panel screws that hold plate over SCAN connector hole.
3. Install SCAN card inside rear panel using two screws removed in Step 2.
4. Plug the SCAN card ribbon cable into the plug marked “ “ on the MAIN board (P/N 48-90529-034).
5. Replace top cover by sliding it into the front panel groove. Secure with the four (4) screws from Step1.

### 3.5.3 Scanner Connections

Before connecting the scanner to the Guardian 500VA or connecting devices for test **Press the [STOP] key** and make sure the red DANGER light is **OFF**. Figure 3-8 illustrates the connection of the G500VA to the 5000-01 Scanner(s) for hipot or insulation resistance (IR) tests.

The G17 25-PIN SCAN control cable is connected from the G500VA rear panel SCAN connector to the 5000-01 rear panel SCAN I/P connector.

The G18 lead set connects the HV terminals. The white 'star' banana plug is connected to the G500VA front panel HV output terminal and the red banana plug is connected to the 5000-01 front panel HV I/P terminal.

The G19 lead set connects the GND terminals. The black banana plug with retaining bracket is connected to the G500VA front panel GND output terminal and the black banana plug is connected to the 5000-01 front panel LOW I/P terminal.

Interconnect the Rear Panel Ground Lugs (Chassis Ground, silver screw/banana plug) using a banana plug to banana plug cable or spade clip to spade clip cable. **This assures that the scanner(s) retains connection to protective earth ground.**

**WARNING**

THE REAR PANEL GROUND LUGS ON ALL INSTRUMENTS (Guardian 500VA and Scanners) MUST BE INTERCONNECTED

### 3.3.4 External Scanner Programming

There are 16 indicators (8 high, 8 low) on the scanner front panel, during test these indicate which are programmed for the High Voltage or Low connections. Connections for high voltage are indicated in red and low in green. When the scanner and Guardian 500VA are connected (25 pin interconnect cable) the instrument will accept entry of scanner connections. A **High** or **Low** entry is made during the programming process preceding the entry of a test voltage. It is possible to have one or multiple entries for scanner connections, i.e. if 1, 2 and 3 are entered for the Hi connection all three outputs will be connected to the High Voltage terminal during the test.

#### **Programmed Scanner Connections: One Scanner**

When using one scanner, the **scan box channels 1-8** can be programmed high or low prior to entering the test voltage. Use the numerical keys and enter high scan channels. Press [ENTER]. Use the numerical keys and enter low scan channels. Press [ENTER].

High = 1 2 3 Scan Box-Channel 1
------------------------------------

Low = 4 5 6 7 8 Scan Box-Channel 1
---------------------------------------

#### **Programmed Scanner Connections: Multiple Scanners**

When using more than one scanner, the **initial parameter setting: Scan No** must be setup for the number of scanners connected. Refer to paragraph 2.10. Connection of up to 2 scanners (5000-01) for hipot or IR testing is possible for a total of 16 channels. When programming scanner connections the scanner number (1 through 8) is shown on the display.

#### **NOTE**

When the scanner is programmed for multiple connections in the same test step the devices under test are connected in parallel (as shown in Figure 3.8). To test several devices independent from each other, requires an individual test step for each. Refer to paragraphs 2.3 – 2.6.

## External Scanner Connection

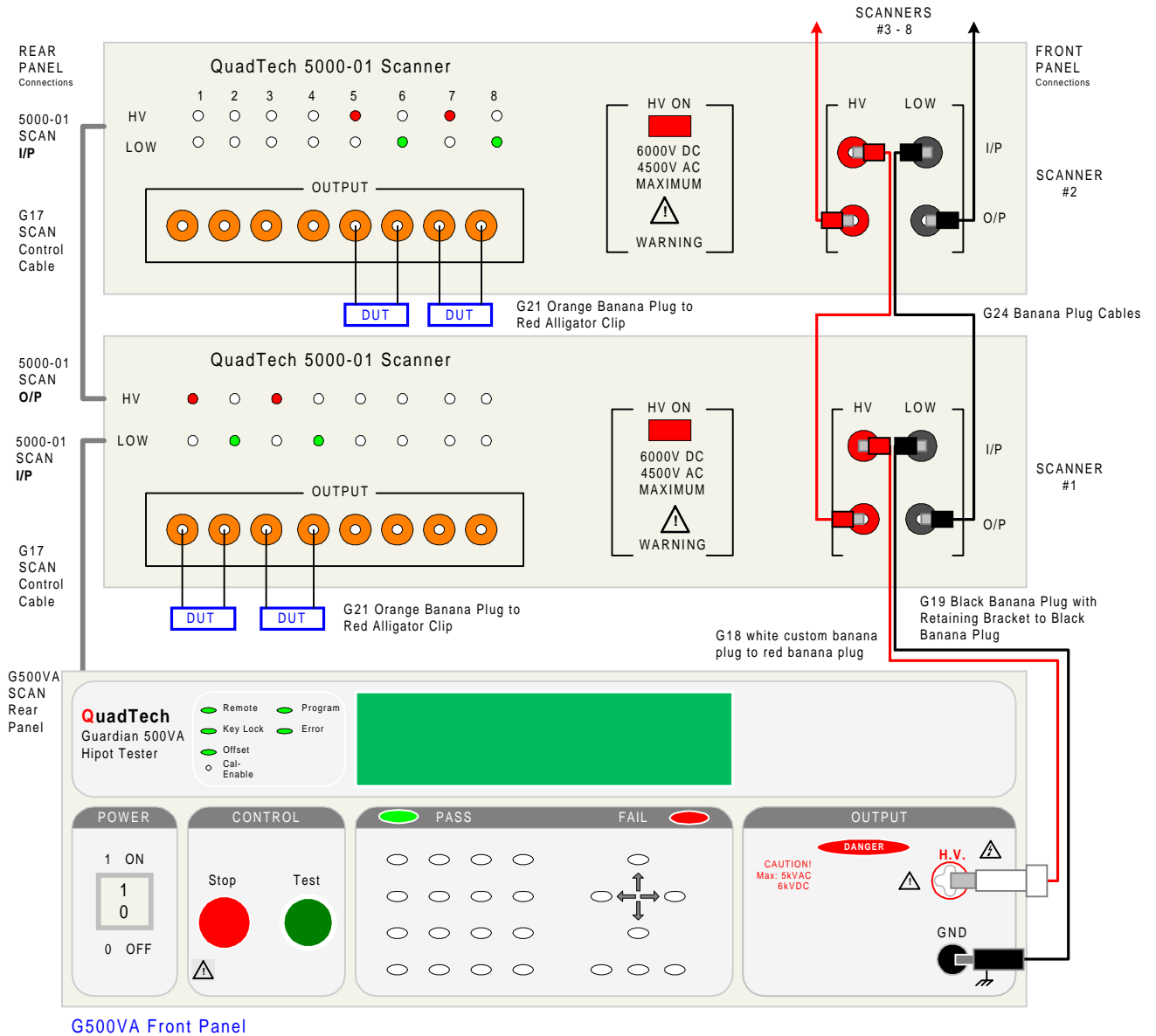

**Figure 3-8: Guardian 500VA Connection to 5000-01 Multiple External Scanners (AC/DC Hipot & Insulation Resistance Tests)**



### 3.6 G16 International Power Strip

The G16 International Power Strip allows connection of standard corded products from several different countries. These countries are:

- |                 |                  |               |
|-----------------|------------------|---------------|
| * Australia     | * United Kingdom | * Denmark     |
| * North America | * Norway         | * Finland     |
| * Sweden        | * Germany        | * Netherlands |
| * Austria       | * Switzerland    | * Italy       |

Refer to Figure 3-9 for connection of the G16 International Power Strip to the Guardian 500VA, 10kVAC or 12kVDC instrument.

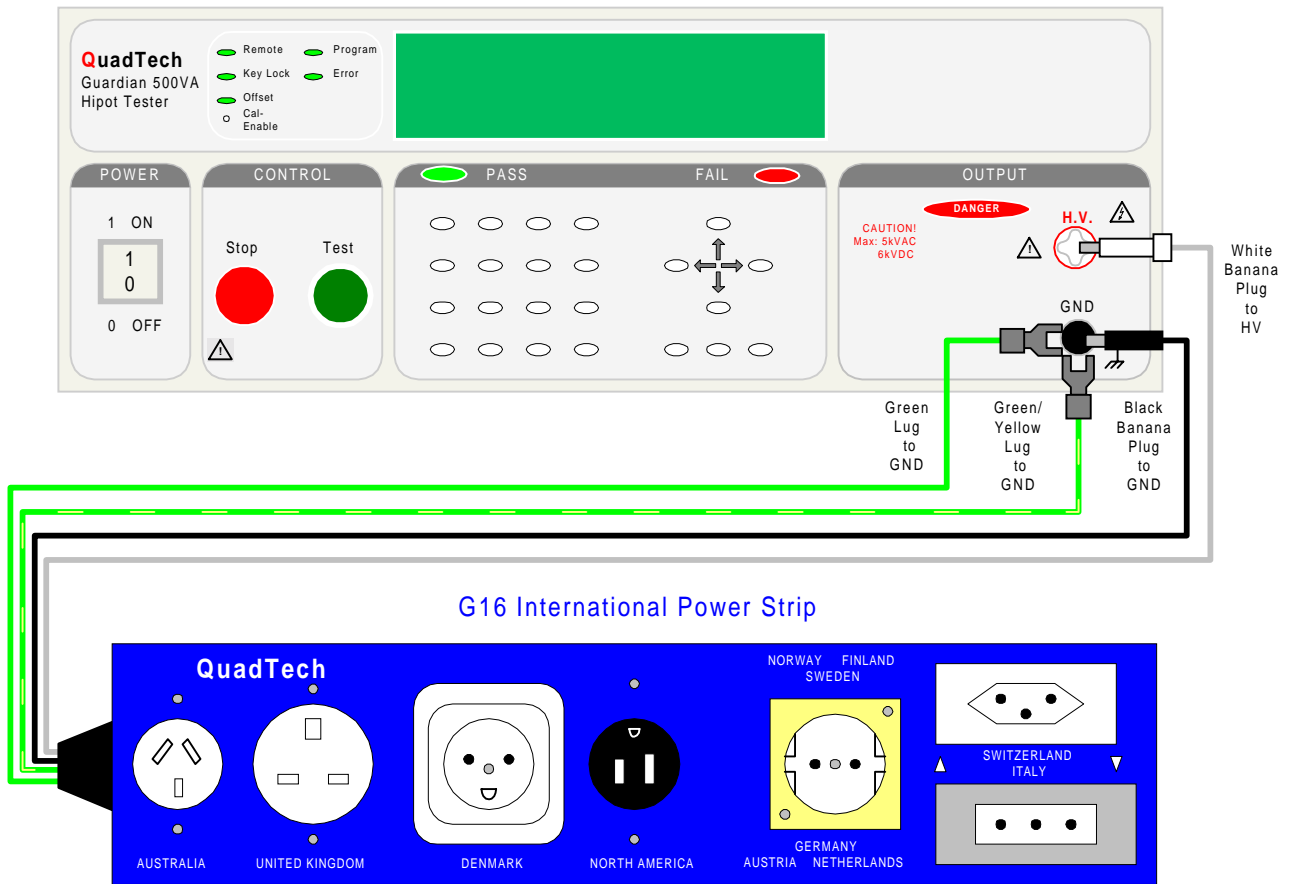

**Figure 3-9: G16 International Power Strip Connection**

### 3.7 S07 Power Entry Adaptor Cable

The S07 (or G14) Power Entry Adaptor Cable allows an AC inlet connection of product to the Guardian 500VA, 10kVAC or 12kVDC unit through a three lead set. The leads consist of a white 'star' banana plug for connection to the HV output, a black banana plug with retaining bracket for connection to the GND terminal and a black spade lug also for connection to GND. Figure 3-10 illustrates the connection of the S07 Power Entry Adaptor Cable to the Guardian 500VA, 10kVAC or 12kVDC unit.

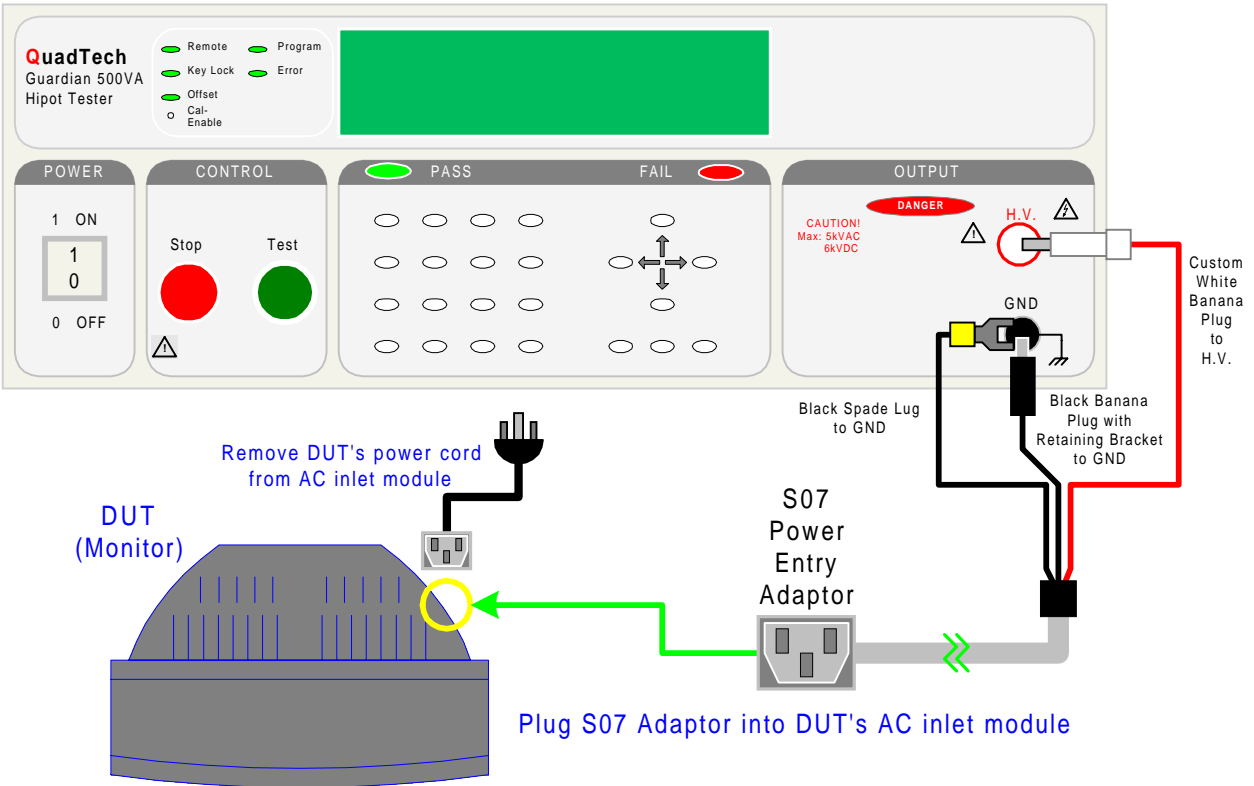
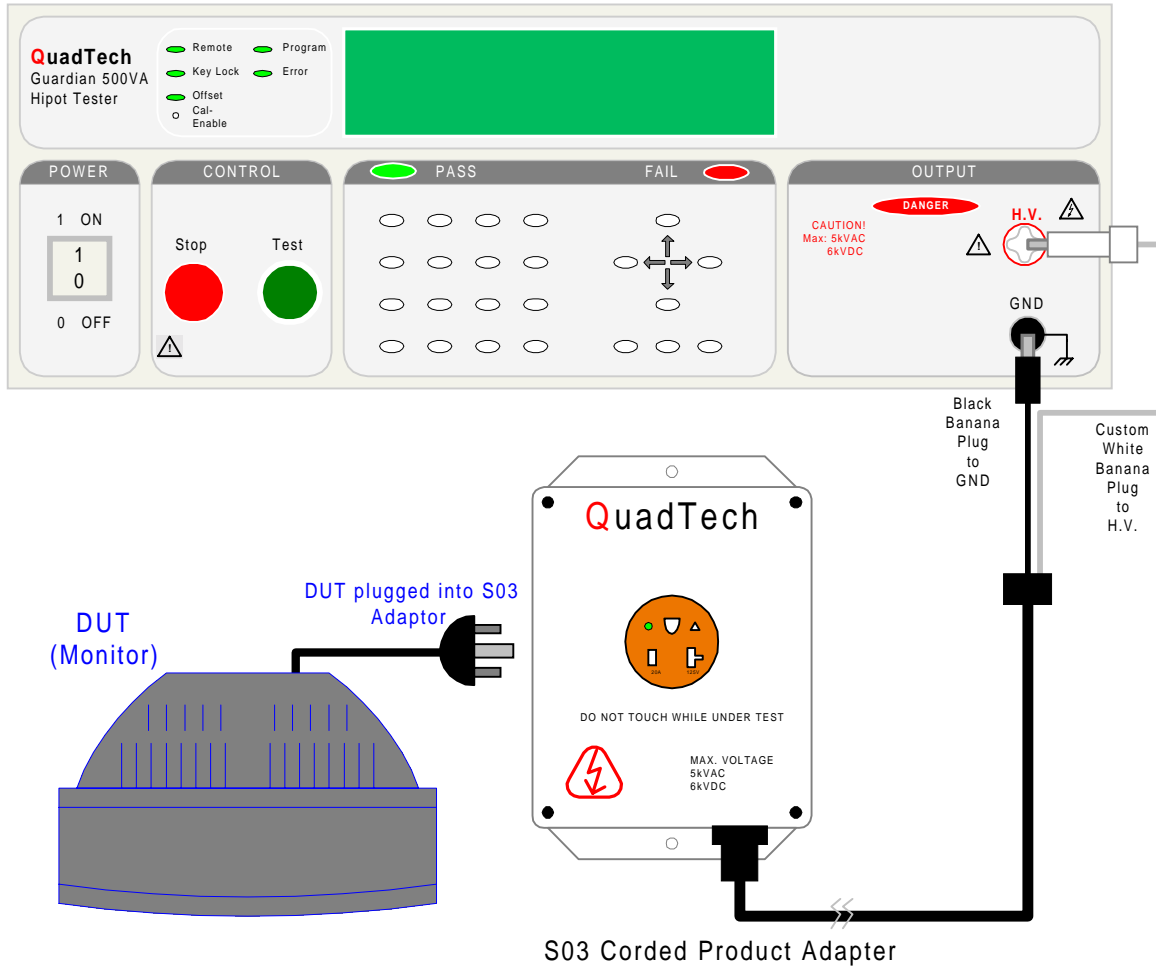

Figure 3-10: S07 Connection to Guardian 500VA, 10kVAC or 12kVDC

### 3.8 S03 Corded Product Adaptor

The S03 Corded Product Adaptor provides a three-prong receptacle connection for product to the Guardian 500VA, 10kVAC or 12kVDC instrument through a two lead set. The leads consist of a white 'star' banana plug for connection to **HV OUTPUT** terminal and a black banana plug for connection to the **GND OUTPUT** terminal. Figure 3-11 illustrates the connection of the S03 Corded Product Adaptor to the Guardian 500VA, 10kVAC or 12kVDC unit.



**Figure 3-11: S03 Connection to Guardian 500VA, 10kVAC or 12kVDC**



---

## Section 4 : Service & Calibration

---

### 4.1 General

Our warranty (at the front of the manual) attests to the quality of materials and workmanship in our products. If malfunction should be suspected, or other information be desired applications engineers are available for technical assistance. Application assistance is available in the U.S. by calling 978-461-2100 and asking for Applications Support. For support outside of the United States please contact your local QuadTech distributor.

### 4.2 Instrument Return

Before returning an instrument to QuadTech for service please call our **Customer Care Center (CCC)** at **800-253-1230** for Return Material Authorization (RMA). It will be necessary to include a Purchase Order Number to insure expedient processing, although units found to be in warranty will be repaired at no-charge. For any questions on repair costs or shipment instructions please contact our CCC Department at the above number. To safeguard an instrument during storage and shipping please use packaging that is adequate to protect it from damage, i.e., equivalent to the original packaging and mark the box "Delicate Electronic Instrument". Return material should be sent freight prepaid, to:

QuadTech, Inc.  
5 Clock Tower Place, 210 East  
Maynard, MA 01754

Attention: RMA #

**Shipments sent collect cannot be accepted.**

### 4.3 Calibration

Calibration of the Guardian 500VA, 10kVAC and 12kVDC instruments is recommended on an annual basis. If the unit is returned to QuadTech for factory calibration refer to paragraph 4.2 for instructions. Using the calibration procedure below the instrument can be calibrated by a qualified service person if traceable calibration equipment and standards are available. **The instrument should be powered up for a minimum of 1 hour before calibration to ensure maximum stability.**

**Table 4-1 : Calibration Equipment**

<b>Equipment</b>	<b>Parameter</b>	<b>Requirements</b>
AC/DC High Voltage Voltmeter		Measure Range : 0 to 6KV, 0.1% accuracy
AC/DC Current Meter		Measure Range : 0 to 40mA, 0.1% accuracy
1GΩ Resistance Standard	IR Resistor	250V
100MΩ Resistance Standard	IR Resistor	500V
10MΩ Resistance Standard	IR Resistor AC & DC Current	500V & 1000V 1200V, 0.1mA, .25W
480KΩ Resistance Standard	AC & DC Current	1200V, 3mA, 50W
250KΩ Resistance Standard	ARCing	1250V, 5mA, 5W
80KΩ Resistance Standard	DC Current	1200V, 15mA, 100W
45KΩ Resistance Standard	AC Current	1200V, 25mA, 200W

**4.3.1 Calibration Procedure**

To avoid confusion and to fully illustrate the calibration of the three Guardian instruments described in this instruction manual, all three calibration procedures are included in Section 4.0. Refer to paragraph 4.3.2 for Guardian 500VA calibration. Refer to paragraph 4.3.3 for Guardian 10kVAC calibration. Refer to paragraph 4.3.4 for Guardian 12kVDC calibration. Calibration of all instruments is initiated (enabled) by pressing [ENTER] [7] [9] [3] [1] and following the instructions below.

**To Enable Calibration:**

With the instrument in standby status (Stop button previously pressed and no lights flashing) remove the front panel calibration seal and push (using tip of small screw driver or pen point) the recessed switch through the hole in the front panel labeled Cal- Enable (to the in position).

**Press [BUTTON]:**

**Display Reads:**

[ENTER] [7] [9] [3] [1]

Calibrate is ON Press OFF key.
-----------------------------------

[Off] (until display reads 'Calibrate is Test')

Calibrate is Test Press OFF key.
-------------------------------------

[PROG] (to enter Calibration)

Cal ACV 5kV Offset 0.050kV
-------------------------------

### 4.3.2 Guardian 500VA Calibration

The procedure to calibrate a Guardian 500VA unit is divided into seven (7) parts: AC Voltage, DC Voltage, IR Voltage, AC Current, DC Current, ARCing and IR Resistor. Table 4-2 contains the calibration parameters for the Guardian 500VA unit tests.

**Table 4-2: G500VA Calibration Parameters**

TEST		RANGE		CAL. POINT
<b>Voltage Calibration</b>				
CAL	ACV	5kV	Offset	0.050kV
CAL	ACV	5kV	Full	4.000kV
CAL	DCV	6kV	Offset	0.050kV
CAL	DCV	6kV	Full	4.000kV
CAL	IRV	1kV	Offset	0.050kV
CAL	IRV	1kV	Full	1.000kV
<b>Current Calibration</b>				
CAL	ACA	3mA	Offset	0.120mA
CAL	ACA	3mA	Full	2.500mA
CAL	ACA	100mA	Offset	2.50mA
CAL	ACA	100mA	Full	25.00mA
CAL	DCA	3mA	Offset	0.120mA
CAL	DCA	3mA	Full	2.500mA
CAL	DCA	20mA	Offset	2.50mA
CAL	DCA	20mA	Full	12.00mA
<b>WAC and WDC ARCing Calibration</b>				
CAL	AC ARC	40mA	Arc	5.00mA
CAL	DC ARC	20mA	Arc	5.00mA
<b>IR Resistor Mode Calibration</b>				
CAL	RnG0	1.00 GΩ	IRR	Range 1 to 1.00 GΩ
CAL	RnG1	100.0 MΩ	IRR	Range 2 to 100.0 MΩ
CAL	RnG2	10.0 MΩ	IRR	Range 3 to 10.0 MΩ
CAL	RnG3	10.0 MΩ	IRR	Range 4 to 10.0 MΩ

**NOTE**

Pressing the [↑] key at any time during calibration allows the operator to scroll through the calibration steps.

The [OFF] key enters the operator into that particular calibration step.

The [STOP] key accepts the calibration value.

### 4.3.2.1 AC Voltage Calibration

Connect the AC voltmeter between the HV and GND OUTPUT terminals.

#### ACV 5kV Offset & Full:

Press [BUTTON]:



[Off]

[STOP] [TEST]

(Read Voltage from voltmeter. Example: 0.062kV)

[0] [.] [0] [6] [2] [ENTER]

[STOP]



[Off]

[STOP] [TEST]

(Read Voltage from voltmeter. Example: 4.052kV)

[4] [.] [0] [5] [2] [ENTER]

[STOP]

Display Reads:

Cal ACV 5kV Offset 0.050kV
-------------------------------

Step-01	0.0s
0.050kV WAC	0.500mA

Step-01	30.0s
---------	-------

Step-01	30.0s
---------	-------

Step-01	0.0s
0.050kV WAC	0.500mA

Cal ACV 5kV Full 4.000kV
-----------------------------

Step-01	0.0s
4.000kV WAC	0.500mA

Step-01	30.0s
---------	-------

Step-01	30.0s
---------	-------

Step-01	0.0s
4.000V WAC	0.500mA



### 4.3.2.2 DC Voltage Calibration

Connect the DC voltmeter between the HV and GND OUTPUT terminals.

#### DCV 6kV Offset & Full:

Press [BUTTON]:



[Off]

[STOP] [TEST]

(Read Voltage from voltmeter. Example: 0.062kV)

[0] [.] [0] [6] [2] [ENTER]

[STOP]



[Off]

[STOP] [TEST]

(Read Voltage from voltmeter. Example: 4.052kV)

[4] [.] [0] [5] [2] [ENTER]

[STOP]

Display Reads:

Cal DCV 6kV Offset 0.050kV
-------------------------------

Step-01	0.0s
0.050kV WDC	0.500mA

Step-01	30.0s
---------	-------

Step-01	30.0s
---------	-------

Step-01	0.0s
0.050kV WDC	0.500mA

Cal DCV 6kV Full 4.000kV
-----------------------------

Step-01	0.0s
4.000kV WDC	0.500mA

Step-01	30.0s
---------	-------

Step-01	30.0s
---------	-------

Step-01	0.0s
4.000V WDC	0.500mA

### 4.3.2.3 IR Voltage Calibration

Connect the DC voltmeter between the HV and GND OUTPUT terminals.

#### IRV 1kV Offset & Full:

Press [BUTTON]:



[Off]

[STOP] [TEST]

(Read Voltage from voltmeter. Example: 0.062kV)

[0] [.] [0] [6] [2] [ENTER]

[STOP]



[Off]

[STOP] [TEST]

(Read Voltage from voltmeter. Example: 1.052kV)

[1] [.] [0] [5] [2] [ENTER]

[STOP]

Display Reads:

Cal IRV 1kV Offset 0.050kV
-------------------------------

Step-01	0.0s
0.050kV IR	1.0M $\Omega$

Step-01	30.0s
---------	-------

Step-01	30.0s
---------	-------

Step-01	0.0s
0.050kV IR	1.0M $\Omega$

Cal IRV 1kV Full 1.000kV
-----------------------------

Step-01	0.0s
1.000kV IR	1.0M $\Omega$

Step-01	30.0s
---------	-------

Step-01	30.0s
---------	-------

Step-01	0.0s
1.000kV IR	1.0M $\Omega$

#### 4.3.2.4 AC Current Calibration

Connect a load resistor (10 MΩ) between the HV OUTPUT terminal of the Guardian 500VA and the High terminal of the AC ammeter. Connect the Low terminal of the AC ammeter to the GND terminal (black) of the Guardian 500VA.

##### ACA 3mA Offset & Full:

Press [BUTTON]:



[Off]

[STOP] [TEST]

(Read Voltage from voltmeter. Example: 0.124mA)

[0] [.] [1] [2] [4] [ENTER]

[STOP]

**(Change Load Resistor to 480kΩ, >50W)**



[Off]

[STOP] [TEST]

(Read Voltage from voltmeter. Example: 2.903mA)

[2] [.] [9] [0] [3] [ENTER]

[STOP]

Display Reads:

Cal ACA 3mA Offset
0.120mA

Step-01	0.0s
1.200kV WAC	2.999mA

Step-01	30.0s
---------	-------

Step-01	30.0s
---------	-------

Step-01	0.0s
1.200kV WAC	2.999mA

Cal ACA 3mA Full
2.500mA

Step-01	0.0s
1.200kV WAC	2.999mA

Step-01	30.0s
---------	-------

Step-01	30.0s
---------	-------

Step-01	0.0s
1.200kV WAC	2.999mA

## ACA 100mA Offset & Full:

Press [BUTTON]:



[Off]

[STOP] [TEST]

(Read Voltage from voltmeter. Example: 2.413mA)

[2] [.] [4] [1] [3] [ENTER]

[STOP]

**(Change Load Resistor to 45kΩ, >200W)**



[Off]

[STOP] [TEST]

(Read Voltage from voltmeter. Example: 24.50mA)

[2] [4] [.] [5] [0] [ENTER]

[STOP]

Display Reads:

Cal ACA 100mA Offset 2.50mA
--------------------------------

Step-01	0.0s
1.200kV WAC	30.00mA

Step-01	30.0s
---------	-------

Step-01	30.0s
---------	-------

Step-01	0.0s
1.200kV WAC	30.00mA

Cal ACA 100mA Full 25.00mA
-------------------------------

Step-01	0.0s
1.200kV WAC	30.00mA

Step-01	30.0s
---------	-------

Step-01	30.0s
---------	-------

Step-01	0.0s
1.200kV WAC	30.00mA

### 4.3.2.5 DC Current Calibration

Connect a load resistor (10 MΩ) between the HV OUTPUT terminal of the Guardian 500VA and the High terminal of the DC ammeter. Connect the Low terminal of the DC ammeter to the GND terminal (black) of the Guardian 500VA.

#### DCA 3mA Offset & Full:

Press [BUTTON]:



[Off]

[STOP] [TEST]

(Read Voltage from voltmeter. Example: 0.124mA)

[0] [.] [1] [2] [4] [ENTER]

[STOP]

**(Change Load Resistor to 480kΩ, >50W)**



[Off]

[STOP] [TEST]

(Read Voltage from voltmeter. Example: 2.413mA)

[2] [.] [4] [1] [3] [ENTER]

[STOP]

Display Reads:

Cal DCA 3mA Offset
0.120mA

Step-01	0.0s
1.200kV WDC	2.999mA

Step-01	30.0s
---------	-------

Step-01	30.0s
---------	-------

Step-01	0.0s
1.200kV WDC	2.999mA

Cal DCA 3mA Full
2.500mA

Step-01	0.0s
1.200kV WDC	2.999mA

Step-01	30.0s
---------	-------

Step-01	30.0s
---------	-------

Step-01	0.0s
1.200kV WDC	2.999mA

## DCA 20mA Offset & Full:

Press [BUTTON]:



[Off]

[STOP] [TEST]

(Read Voltage from voltmeter. Example: 2.503mA)

[2] [.] [5] [0] [3] [ENTER]

[STOP]

**(Change Load Resistor to 80kΩ, >100W)**



[Off]

[STOP] [TEST]

(Read Voltage from voltmeter. Example: 14.82mA)

[1] [4] [.] [8] [2] [ENTER]

[STOP]

Display Reads:

Cal DCA 20mA Offset 2.500mA
--------------------------------

Step-01	0.0s
1.200kV WDC	15.00mA

Step-01	30.0s
---------	-------

Step-01	30.0s
---------	-------

Step-01	0.0s
1.200kV WDC	15.00mA

Cal DCA 20mA Full 12.00mA
------------------------------

Step-01	0.0s
1.200kV WDC	15.00mA

Step-01	30.0s
---------	-------

Step-01	30.0s
---------	-------

Step-01	0.0s
1.200kV WDC	15.00mA

### 4.3.2.6 WAC and WDC ARCing Calibration

Connect a load resistor of **250K $\Omega$**  (5 watt). Connect an AC current meter.

**NOTE:**  
Arcing calibration range value is 0.1 – 9.9mA.  
During calibration the arcing value is changed to ARCing NG.

#### AC ARC 40mA & DC ARC 20mA:

**Press [BUTTON]:**

**Display Reads:**

↑

Cal AC ARC 40mA  
5.00mA

[Off]

Step-01            0.0s  
1.250kV WAC 10.00mA

[STOP] [TEST]

Step-01            30.0s

(Read Current from current meter. Example: 5.049mA)

[5] [.] [0] [4] [9]            [ENTER]

Step-01            30.0s

[STOP]

Step-01            0.0s  
1.250kV WAC 10.00mA

↑

Cal DC ARC 20mA  
5.00mA

[Off]

Step-01            0.0s  
1.250kV WDC 10.00mA

[STOP] [TEST]

Step-01            30.0s

(Read Current from current meter. Example: 5.051mA)

[5] [.] [0] [5] [1]            [ENTER]

Step-01            30.0s

[STOP]

Step-01            0.0s  
1.250kV WDC 10.00mA

### 4.3.2.7 IR Resistor Calibration

Connect a 1G $\Omega$  load resistor between the HV and GND OUTPUT terminals.

#### NOTE

Upon entering the calibrated value of the resistance standard, the G500VA unit may respond with a low limit failure. (FAIL LED lights, Display indicates “low limit failure”). This is normal. Proceed with remaining calibration steps.

#### IRR Range 0 and Range 1:

Press [BUTTON]:



[Off]

[STOP] [TEST]

(Enter calibrated value of Resistance Standard. Example: 1000.01 Mohms)

[1] [0] [0] [0] [.] [0] [1] [ENTER]

[STOP]

**(Change the load resistor to 100M $\Omega$ )**



[Off]

[STOP] [TEST]

(Enter calibrated value of Resistance Standard. Example: 100.01Mohms)

[1] [0] [0] [.] [0] [1] [ENTER]

[STOP]

Display Reads:

Cal IRR Range0  
1.00G  $\Omega$

Step-01 0.0s  
0.250kV IR 1.0M  $\Omega$

Step-01 30.0s

Step-01 30.0s

Step-01 0.0s  
0.250kV IR 1.0M  $\Omega$

Cal IRR Range1  
100.0M  $\Omega$

Step-01 0.0s  
0.500kV IR 1.0M  $\Omega$

Step-01 30.0s

Step-01 30.0s

Step-01 0.0s  
0.500kV IR 1.0M  $\Omega$



## Change the load resistor to 10MΩ

### IRR Range 2 and Range 3:

Press [BUTTON]:



[Off]

[STOP] [TEST]

(Enter calibrated value of Resistance Standard. Example: 10.01 Mohms)

[1] [0] [.] [0] [1] [ENTER]

[STOP]

**(Use the same 10Mohm load resistor)**



[Off]

[STOP] [TEST]

(Enter calibrated value of Resistance Standard. Example: 10.01Mohms)

[1] [0] [.] [0] [1] [ENTER]

[STOP]

Display Reads:

Cal IRR Range2 10.0M Ω
---------------------------

Step-01	0.0s
0.500kV IR	1.0M Ω

Step-01	30.0s
---------	-------

Step-01	30.0s
---------	-------

Step-01	0.0s
0.500kV IR	1.0M Ω

Cal IRR Range3 10.0M Ω
---------------------------

Step-01	0.0s
0.500kV IR	1.0M Ω

Step-01	30.0s
---------	-------

Step-01	30.0s
---------	-------

Step-01	0.0s
1.000kV IR	1.0M Ω

### 4.3.2.8 Finalize Calibration

Press [BUTTON]:

[ENTER] [7] [9] [3] [1]

[Off] (until display reads 'Calibrate is ON')

[PROG] (to exit Calibration)

Display Reads:

Calibrate is Test Press OFF key.
-------------------------------------

Calibrate is ON Press OFF key.
-----------------------------------

Step-01	0.0s
1.000kV WAC	3.0mA

Press the lock switch labeled Cal-Enable (to the **OUT** position) and cover with a calibration label.

### 4.3.3 Guardian 10kVAC Calibration

The procedure to calibrate a Guardian 10kVAC instrument is divided into three (3) parts: AC Voltage, AC Current and ARCing. Table 4-3 contains the calibration parameters for the Guardian 10kVAC instrument tests.

**Table 4-3: G10kVAC Calibration Parameters**

TEST		RANGE		CAL. POINT
<b>Voltage Calibration</b>				
CAL	ACV	10kV	Offset	0.10kV
CAL	ACV	10kV	Full	6.00kV
<b>Current Calibration</b>				
CAL	ACA	3mA	Offset	0.120mA
CAL	ACA	3mA	Full	2.500mA
CAL	ACA	20mA	Offset	2.50mA
CAL	ACA	20mA	Full	15.00mA
<b>WAC and WDC ARCing Calibration</b>				
CAL	AC ARC	40mA	Arc	5.00mA

**NOTE**

Pressing the [↑] key at any time during calibration allows the operator to scroll through the calibration steps.

The [OFF] key enters the operator into that particular calibration step.

The [STOP] key accepts the calibration value.

### 4.3.3.1 AC Voltage Calibration

Connect the AC voltmeter between the HV and GND OUTPUT terminals.

#### ACV 10kV Offset & Full:

Press [BUTTON]:



[Off]

[STOP] [TEST]

(Read Voltage from voltmeter. Example: 0.982kV)

[0] [.] [9] [8] [2] [ENTER]

[STOP]



[Off]

[STOP] [TEST]

(Read Voltage from voltmeter. Example: 6.052kV)

[6] [.] [0] [5] [2] [ENTER]

[STOP]

Display Reads:

Cal ACV 10kV Offset 0.10kV
-------------------------------

Step-01	0.0s
0.10kV WAC	0.500mA

Step-01	30.0s
---------	-------

Step-01	30.0s
---------	-------

Step-01	0.0s
0.10kV WAC	0.500mA

Cal ACV 10kV Full 6.00kV
-----------------------------

Step-01	0.0s
6.00kV WAC	0.500mA

Step-01	30.0s
---------	-------

Step-01	30.0s
---------	-------

Step-01	0.0s
6.00V WAC	0.500mA

### 4.3.3.2 AC Current Calibration

Connect a load resistor (10 MΩ) between the HV OUTPUT terminal of the Guardian 10kVAC and the High terminal of the AC ammeter. Connect the Low terminal of the AC ammeter to the GND terminal (black) of the Guardian 10kVAC.

#### ACA 3mA Offset & Full:

Press [BUTTON]:



[Off]

[STOP] [TEST]

(Read Voltage from voltmeter. Example: 0.124mA)

[0] [.] [1] [2] [4] [ENTER]

[STOP]

**(Change Load Resistor to 480kΩ, >50W)**



[Off]

[STOP] [TEST]

(Read Voltage from voltmeter. Example: 2.903mA)

[2] [.] [9] [0] [3] [ENTER]

[STOP]

Display Reads:

Cal ACA 3mA Offset
0.120mA

Step-01	0.0s
1.200kV WAC	2.999mA

Step-01	30.0s
---------	-------

Step-01	30.0s
---------	-------

Step-01	0.0s
1.200kV WAC	2.999mA

Cal ACA 3mA Full
2.500mA

Step-01	0.0s
1.200kV WAC	2.999mA

Step-01	30.0s
---------	-------

Step-01	30.0s
---------	-------

Step-01	0.0s
1.200kV WAC	2.999mA

## ACA 20mA Offset & Full:

Press [BUTTON]:



[Off]

[STOP] [TEST]

(Read Voltage from voltmeter. Example: 2.413mA)

[2] [.] [4] [1] [3] [ENTER]

[STOP]

**(Change Load Resistor to 80kΩ, >200W)**



[Off]

[STOP] [TEST]

(Read Voltage from voltmeter. Example: 14.50mA)

[1] [4] [.] [5] [0] [ENTER]

[STOP]

Display Reads:

Cal ACA 20mA Offset 2.50mA
-------------------------------

Step-01	0.0s
1.200kV WAC	30.00mA

Step-01	30.0s
---------	-------

Step-01	30.0s
---------	-------

Step-01	0.0s
1.200kV WAC	30.00mA

Cal ACA 20mA Full 15.00mA
------------------------------

Step-01	0.0s
1.200kV WAC	30.00mA

Step-01	30.0s
---------	-------

Step-01	30.0s
---------	-------

Step-01	0.0s
1.200kV WAC	30.00mA

### 4.3.3.3 WAC ARCing Calibration

Connect a load resistor of **250KΩ** (5 watt). Connect an AC current meter.

**NOTE:**  
Arcing calibration range value is 0.1 – 9.9mA.  
During calibration the arcing value is changed to ARCing NG.

#### AC ARC 40mA:

Press [BUTTON]:



[Off]

[STOP] [TEST]

(Read Current from current meter. Example: 5.049mA)

[5] [.] [0] [4] [9] [ENTER]

[STOP]

Display Reads:

Cal AC ARC 40mA  
5.00mA

Step-01 0.0s  
1.250kV WAC 10.00mA

Step-01 30.0s

Step-01 30.0s

Step-01 0.0s  
1.250kV WAC 10.00mA

#### 4.3.3.4 Finalize Calibration

Press [BUTTON]:

[ENTER] [7] [9] [3] [1]

[Off] (until display reads 'Calibrate is ON')

[PROG] (to exit Calibration)

Display Reads:

Calibrate is Test  
Press OFF key.

Calibrate is ON  
Press OFF key.

Step-01 0.0s  
1.000kV WAC 3.0mA

Press the lock switch labeled Cal-Enable (to the **OUT** position) and cover with a calibration label.

#### 4.3.4 Guardian 12kVDC Calibration

The procedure to calibrate a Guardian 12kVDC unit is divided into five (5) parts: DC Voltage, IR Voltage, DC Current, ARCing and IR Resistor. Table 4-4 contains the calibration parameters for the Guardian 12kVDC unit tests.

**Table 4-4: G12kVDC Calibration Parameters**

TEST		RANGE		CAL. POINT
<b>Voltage Calibration</b>				
CAL	DCV	12kV	Offset	0.10kV
CAL	DCV	12kV	Full	6.00kV
CAL	IRV	1kV	Offset	0.050kV
CAL	IRV	1kV	Full	1.00kV
<b>Current Calibration</b>				
CAL	DCA	3mA	Offset	0.120mA
CAL	DCA	3mA	Full	2.500mA
CAL	DCA	10mA	Offset	2.50mA
CAL	DCA	10mA	Full	8.00mA
<b>WAC and WDC ARCing Calibration</b>				
CAL	DC ARC	20mA	Arc	5.00mA
<b>IR Resistor Mode Calibration</b>				
CAL	RnG0	1.00 GΩ	IRR	Range 1 to 1.00 GΩ
CAL	RnG1	100.0 MΩ	IRR	Range 2 to 100.0 MΩ
CAL	RnG2	10.0 MΩ	IRR	Range 3 to 10.0 MΩ
CAL	RnG3	10.0 MΩ	IRR	Range 4 to 10.0 MΩ

**NOTE**

Pressing the [↑] key at any time during calibration allows the operator to scroll through the calibration steps.

The [OFF] key enters the operator into that particular calibration step.

The [STOP] key accepts the calibration value.



### 4.3.4.1 DC Voltage Calibration

Connect the DC voltmeter between the HV and GND OUTPUT terminals.

#### DCV 12kV Offset & Full:

Press [BUTTON]:



[Off]

[STOP] [TEST]

(Read Voltage from voltmeter. Example: 0.982kV)

[0] [.] [9] [8] [2] [ENTER]

[STOP]



[Off]

[STOP] [TEST]

(Read Voltage from voltmeter. Example: 6.052kV)

[6] [.] [0] [5] [2] [ENTER]

[STOP]

Display Reads:

Cal DCV 12kV Offset 0.10kV
-------------------------------

Step-01	0.0s
0.10kV WDC	0.500mA

Step-01	30.0s
---------	-------

Step-01	30.0s
---------	-------

Step-01	0.0s
0.10kV WDC	0.500mA

Cal DCV 12kV Full 6.00kV
-----------------------------

Step-01	0.0s
6.00kV WDC	0.500mA

Step-01	30.0s
---------	-------

Step-01	30.0s
---------	-------

Step-01	0.0s
6.00V WDC	0.500mA

### 4.3.4.2 IR Voltage Calibration

Connect the DC voltmeter between the HV and GND OUTPUT terminals.

#### IRV 1kV Offset & Full:

Press [BUTTON]:



[Off]

[STOP] [TEST]

(Read Voltage from voltmeter. Example: 0.062kV)

[0] [.] [0] [6] [2] [ENTER]

[STOP]



[Off]

[STOP] [TEST]

(Read Voltage from voltmeter. Example: 1.052kV)

[1] [.] [0] [5] [2] [ENTER]

[STOP]

Display Reads:

Cal IRV 1kV Offset 0.050kV
-------------------------------

Step-01	0.0s
0.050kV IR	1.0M Ω

Step-01	30.0s
---------	-------

Step-01	30.0s
---------	-------

Step-01	0.0s
0.050kV IR	1.0M Ω

Cal IRV 1kV Full 1.000kV
-----------------------------

Step-01	0.0s
1.000kV IR	1.0M Ω

Step-01	30.0s
---------	-------

Step-01	30.0s
---------	-------

Step-01	0.0s
1.000kV IR	1.0M Ω

### 4.3.4.3 DC Current Calibration

Connect a load resistor (10 MΩ) between the HV OUTPUT terminal of the Guardian 12kVDC and the High terminal of the DC ammeter. Connect the Low terminal of the DC ammeter to the GND terminal (black) of the Guardian 12kVDC.

#### DCA 3mA Offset & Full:

Press [BUTTON]:



[Off]

[STOP] [TEST]

(Read Voltage from voltmeter. Example: 0.124mA)

[0] [.] [1] [2] [4] [ENTER]

[STOP]

**(Change Load Resistor to 480kohms, >50W)**



[Off]

[STOP] [TEST]

(Read Voltage from voltmeter. Example: 2.413mA)

[2] [.] [4] [1] [3] [ENTER]

[STOP]

Display Reads:

Cal DCA 3mA Offset
0.120mA

Step-01	0.0s
1.200kV WDC	2.999mA

Step-01	30.0s
---------	-------

Step-01	30.0s
---------	-------

Step-01	0.0s
1.200kV WDC	2.999mA

Cal DCA 3mA Full
2.500mA

Step-01	0.0s
1.200kV WDC	2.999mA

Step-01	30.0s
---------	-------

Step-01	30.0s
---------	-------

Step-01	0.0s
1.200kV WDC	2.999mA

## DCA 10mA Offset & Full:

Press [BUTTON]:



[Off]

[STOP] [TEST]

(Read Voltage from voltmeter. Example: 2.503mA)

[2] [.] [5] [0] [3] [ENTER]

[STOP]

**(Change Load Resistor to 80kohms, >100W)**



[Off]

[STOP] [TEST]

(Read Voltage from voltmeter. Example: 7.82mA)

[7] [.] [8] [2] [ENTER]

[STOP]

Display Reads:

Cal DCA 10mA Offset 2.50mA
-------------------------------

Step-01	0.0s
1.200kV WDC	15.00mA

Step-01	30.0s
---------	-------

Step-01	30.0s
---------	-------

Step-01	0.0s
1.200kV WDC	15.00mA

Cal DCA 10mA Full 8.00mA
-----------------------------

Step-01	0.0s
1.200kV WDC	15.00mA

Step-01	30.0s
---------	-------

Step-01	30.0s
---------	-------

Step-01	0.0s
1.200kV WDC	15.00mA

#### 4.3.4.4 WDC ARCing Calibration

Connect a load resistor of **250KΩ** (5 watt). Connect an AC current meter.

**NOTE:**  
Arcing calibration range value is 0.1 – 9.9mA.  
During calibration the arcing value is changed to ARCing NG.

#### DC ARC 20mA:

Press [BUTTON]:

Display Reads:

↑

Cal DC ARC 20mA  
5.00mA

[Off]

Step-01            0.0s  
1.250kV    WDC   10.00mA

[STOP]    [TEST]

Step-01            30.0s

(Read Current from current meter. Example: 5.051mA)

[5] [.] [0] [5] [1]            [ENTER]

Step-01            30.0s

[STOP]

Step-01            0.0s  
1.250kV    WDC   10.00mA

### 4.3.4.5 IR Resistor Calibration

Connect a 1GΩ load resistor between the HV and GND OUTPUT terminals.

#### NOTE

Upon entering the calibrated value of the resistance standard, the G12kVDC unit may respond with a low limit failure. (FAIL LED lights, Display indicates “low limit failure”). This is normal. Proceed with remaining calibration steps.

#### IRR Range 0 and Range 1:

Press [BUTTON]:



[Off]

[STOP] [TEST]

(Enter calibrated value of Resistance Standard. Example: 1000.01 Mohms)

[1] [0] [0] [0] [.] [0] [1] [ENTER]

[STOP]

**(Change the load resistor to 100MΩ)**



[Off]

[STOP] [TEST]

(Enter calibrated value of Resistance Standard. Example: 100.01Mohms)

[1] [0] [0] [.] [0] [1] [ENTER]

[STOP]

Display Reads:

Cal IRR Range0  
1.00GΩ

Step-01 0.0s  
0.250kV IR 1.0M Ω

Step-01 30.0s

Step-01 30.0s

Step-01 0.0s  
0.250kV IR 1.0M Ω

Cal IRR Range1  
100.0MΩ

Step-01 0.0s  
0.500kV IR 1.0M Ω

Step-01 30.0s

Step-01 30.0s

Step-01 0.0s  
0.500kV IR 1.0M Ω

## IRR Range 2 and Range 3:

### Change the load resistor to 10MΩ

Press [BUTTON]:



[Off]

[STOP] [TEST]

(Enter calibrated value of Resistance Standard. Example: 10.01 Mohms)

[1] [0] [.] [0] [1] [ENTER]

[STOP]

(Use the same 10Mohm load resistor )



[Off]

[STOP] [TEST]

(Enter calibrated value of Resistance Standard. Example: 10.01Mohms)

[1] [0] [.] [0] [1] [ENTER]

[STOP]

Display Reads:

Cal IRR Range2 10.0M Ω
---------------------------

Step-01	0.0s
0.500kV IR	1.0M Ω

Step-01	30.0s
---------	-------

Step-01	30.0s
---------	-------

Step-01	0.0s
0.500kV IR	1.0M Ω

Cal IRR Range3 10.0M Ω
---------------------------

Step-01	0.0s
1.000kV IR	1.0M Ω

Step-01	30.0s
---------	-------

Step-01	30.0s
---------	-------

Step-01	0.0s
1.000kV IR	1.0M Ω

#### 4.3.4.6 Finalize Calibration

Press [BUTTON]:

[ENTER] [7] [9] [3] [1]

[Off] (until display reads 'Calibrate is ON')

[PROG] (to exit Calibration)

Display Reads:

Calibrate is Test Press OFF key.
-------------------------------------

Calibrate is ON Press OFF key.
-----------------------------------

Step-01	0.0s
1.000kV WAC	3.0mA

Press the lock switch labeled Cal-Enable (to the **OUT** position) and cover with a calibration label.

#### NOTE

Pressing the [↑] key at any time during calibration permits the operator to scroll through the calibration steps.

The [OFF] key enters the operator into that particular calibration step.

The [STOP] key accepts the calibration value.

#### 4.4 Error Messages

Possible error messages for the Guardian 500VA, 10kVAC & 12kVDC instruments are divided into two categories. There is a set of error messages that apply to the normal operation of the instrument and a second set of error messages that apply to the operation of the instrument with a GPIB (IEEE-488) Interface installed. Refer to Table 4-5.

**Table 4-5: Error Messages**

Operation	Error Number	Message Description
<b>Normal</b>	100	HARDWARE FAILURE
	101	Consult QuadTech for SERVICE
	102	
	Discharging	
<b>GPIB</b>	Error 0	Save OK!
	Error 1	The command is INVALID!
	Error 2	The parameter is INVALID!
	Error 3	TEST can NOT be initiated!
	Error 4	Scan Box is NOT CONNECTED!
	Error 5	Can NOT set Channel # to ZERO!
	Error 6	Set Channel HIGH OR LOW, NOT BOTH!
	Error 7	No DATA to RECALL! (No Data stored in recall location)
Error 8	No MEMORY for STORAGE! (Invalid memory location)	